

OUTDOOR CLASSROOMS

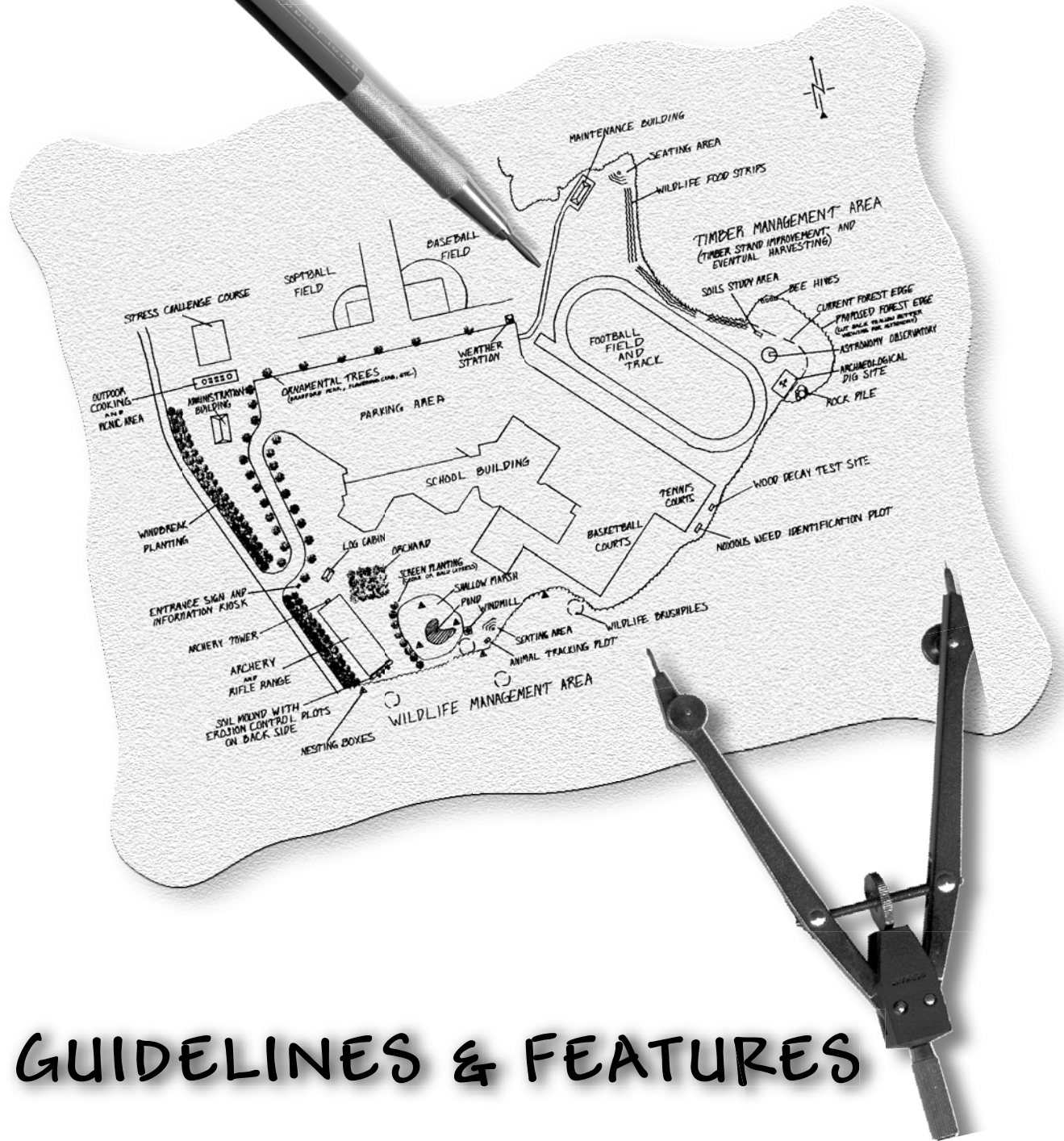

GUIDELINES & FEATURES

Original "Guidelines & Features For Outdoor Classrooms"
developed by Sam Carman, IDNR-Division of Forestry

.....
Redesigned by Deb Fairhurst, Purdue University Cooperative Extension Service

Soil and Water Conservation Districts or Purdue Cooperative Extension Service offices
are excellent resources for local groups wishing to develop an outdoor classroom.

To find the offices in your area of Indiana, go to the following websites:

Soil and Water Conservation District: <http://www.iaswcd.org/contactus.html>

Purdue Cooperative Extension: <http://www.extension.purdue.edu/anr/field/fs/countyoffices2.html>

.....
For educational materials and assistance related to Indiana's natural and cultural
resources, contact the Indiana Department of Natural Resources' education programs:

Forestry: <http://www.in.gov/dnr/forestry/2853.htm>

Fish & Wildlife: <http://www.in.gov/dnr/fishwild/7543.htm>

State Parks & Reservoirs: <http://www.in.gov/dnr/parklake/2389.htm>

Coal Mine Reclamation: <http://www.in.gov/dnr/reclamation/3490.htm>

Historic Preservation & Archaeology: <http://www.in.gov/dnr/historic/5676.htm>



TABLE OF CONTENTS

Introduction	4	Soil Studies	18
Designing an Outdoor Lab Committee	5	Solar/Wind Energy Demonstration	18
Working with the Media	7	Sound Tubes	19
Funding Sources for Outdoor Labs	7	Storage Building	19
Brief Listing of Reference Materials	8	Succession Areas	19
Plant Materials List	9-10	Sundial	19
Maintenance Schedule for Outdoor Labs	11	Time Capsule	19
Animal Tracking Plot	12	Trail	19
Arboretum	12	Tree Cross Sections	19
Archaeological Dig Site	12	Tree Plantation	20
Berry Producing Shrubs	12	Tree Seedling Nursery	20
Bird Blind	12	Watering Hole	20
Bird Feeders	13	Weather Station	20
Bulbs, Corms, and Tubers	13	Whisper Tube	20
Butterfly Garden	13	Wildflower Plot	21
Compost Pile	13	Wildlife Brushpiles	21
Creek	13	Wildlife Food Plots of Grains	21
Dinosaur Study Area	13	Windbreaks of Tree and Shrub Plantings	21
Existing Timber Stand	13	Wood Decay Test Site	21
Erosion Control Demonstration Site	14	Woodland Clearing/Regeneration Area	21
Fence Row	14	Sample Outdoor Lab Plans	22-40
Fossil Path	14		
Grasses Plot	14		
Groundwater Monitoring Hole	14		
Herb Garden	15		
Herbaceous Wildlife Plantings	15		
Horticulture Demonstration and Test Plots	15		
Native American Theme Area	15		
Insect Traps	15		
Lath Structure	15		
Marsh	15		
Milled Sawlog	16		
Natures "Swap Shop"	16		
Nesting Boxes	16		
Orchard	16		
Ornamental Flower Beds	16		
Outdoor Seating Area	17		
Perch n' Plant	17		
Pond	17		
Prairie Plot	17		
Road	17		
Rock Pile, Geological Studies	18		
Sensory Discovery Area	18		
Shelter	18		
Signs	18		
Snow Fence Demonstration	18		





INTRODUCTION

The concept of outdoor laboratories on school sites is popular in Indiana, with hundreds of schools currently developing labs. A great deal has been learned from working with these schools about which procedures tend to be successful and which do not. As you begin to plan for the development of your school's outdoor lab, please consider the following factors and suggestions.

1. Organization

Rambo may have been an interesting movie character, but he probably would not get very far as a teacher proposing an outdoor lab. Yet many labs are attempted by one or two people who take it on as a personal project without the assistance of fellow teachers, administrators or others. The most successful labs are those guided by a standing committee composed of teachers, administrators, buildings and grounds personnel, community members, students, PTA members and any others showing an interest. A broad base of support and expertise is critical to success. Once the committee is formed, sub-committees should be developed to address funding, public awareness and support, curriculum and maintenance (as a minimum).

2. Curriculum

Just as you would not construct a building without specific plans based on solid objectives, so an outdoor lab should not be developed without forethought as to exactly how it will be used. Before the first nail is driven or the first tree is planted, considerable thought must be given to how activities in the proposed outdoor lab will fit into the existing curriculum. How will the outdoor lab help students improve their

proficiencies in all subject areas? Have teachers in all subject areas been consulted as to how they will make use of the outdoor lab and what features would be useful for them to include in the plan? Have teachers received any in-service training in conservation education so that they can become familiar with methods of using the outdoors in their teaching? Unfortunately, outdoor labs have often been developed with only the science subjects in mind; this is like allowing students to use a dictionary only in English class. There are excellent curricular supplements available which use the outdoors to enhance the teaching of any subject.

3. Cost

How much does an outdoor lab cost to develop? Some beautiful, high tech labs have cost schools thousands of dollars to develop. Equally beautiful, simpler labs have been developed with almost no financial output. Cost must certainly be considered, but should not be a deterrent to developing what the staff really wants and will use. What funding, materials and labor the school cannot afford can usually be raised through donations from local individuals and organizations. This highlights the need for a good, solid committee and an effort to make the community aware of the outdoor lab project.

4. Maintenance

While the school custodian takes care of certain maintenance aspects of the indoor classroom, teachers and students are responsible for other maintenance chores. The same is true for the outdoor classroom, except that the role of the teachers and students will usually be more significant. Outdoor labs should be designed to reduce the amount of maintenance needed as much as possible; but there will still be plenty of work to do, and this can be part of the learning experience.

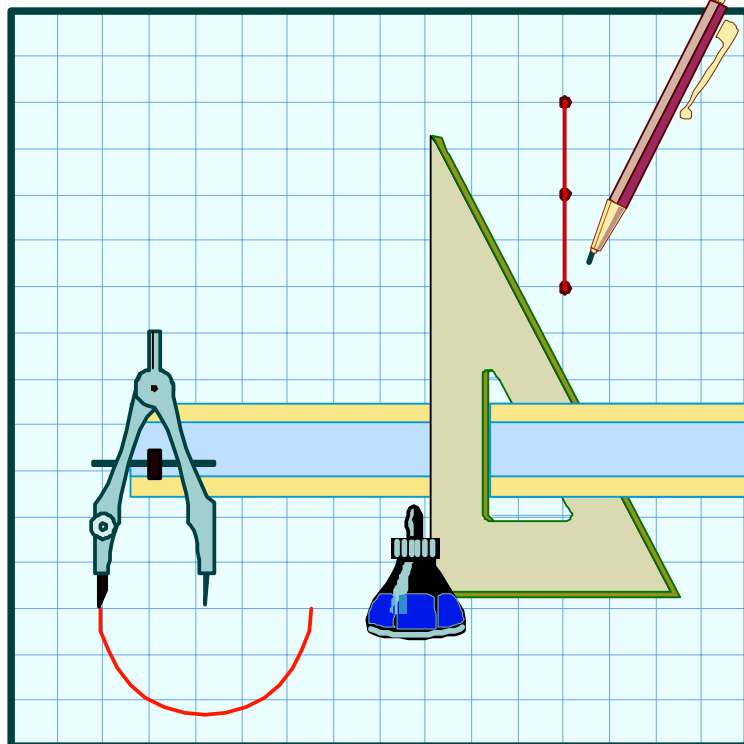

So where do you go from here? After reviewing this publication, first form a committee and meet with them to discuss the items mentioned above. After the committee has determined how the outdoor lab will fit into the curriculum, the committee should then draw a long-term plan to scale of the site and features to be developed.

“Rome wasn’t built in a day,” and neither is an outdoor lab. This whole process may seem rather long and cumbersome, but the end result is well worth the extra effort.



ORGANIZING AN OUTDOOR LAB COMMITTEE

Organizing a permanent committee is the most important step to begin a successful outdoor lab. The committee system has proven to be successful time after time in government affairs and private enterprise. The organization of a committee and the background of its members are very important to insure the outdoor lab is a positive experience for the administration, teachers, students and community.

Why have a committee?

A committee provides a means to use the various backgrounds and talents of its members. A committee will spread the workload, reducing responsibilities of each person. The committee will be the outdoor lab's foundation during planning and throughout development, and insures the project's longevity.

How should the committee be organized?

The committee should be organized immediately after consideration is given to developing the outdoor lab. Organization of the committee is usually done by the person(s) who first initiated the idea of developing an outdoor lab. It should be composed of people who possess positive attitudes and that are committed to conservation and education.

Who should be on the committee?

A committee is made up of any interested volunteers, some with specialized backgrounds. An example of a committee might be:

- Representative teacher from each grade level
- School principal
- School custodian
- Students
- Parents
- Local natural resources professional
- Adjacent landowners

Qualities committee members should possess: ambitious, creative, willingness to work, committed to conservation and education



What are the committee's responsibilities?

The committee will be responsible for the planning, development and proper usage of the outdoor lab facility. To make this committee work efficiently subcommittees should be organized. Three subcommittees are recommended as a minimum.

1. Site Development and Maintenance Sub-committee

Is responsible for overseeing the development of the facility. This begins with gathering information on features (physical, cultural, historical, etc.) already existing around the school that might be used in the outdoor lab. By using school grounds blueprints (if available) or by taking measurements, a map of the school grounds should be made and a plan for the outdoor lab drawn up. Assignments for special tasks would be made by this committee, and assistance by local resource specialists secured. Maintenance duties will also be planned by this committee and responsibilities assigned.

2. Curriculum and Library Sub-committee

Is responsible for collecting educational materials for use in the lab or classroom, and establishment of a library of resource materials for both teacher and student use. The committee will also work with the school administration to schedule conservation education in-service training for teachers. The importance of the sub-committee cannot be over emphasized, as the whole purpose of developing an outdoor lab is to facilitate teaching. Curriculum integration with the outdoor lab must be the first priority.

3. Funding and Public Relations Subcommittee

Is responsible for developing a budget for the outdoor lab and gathering funds to meet the budget (see Funding of the Outdoor Lab). Public relations are also a responsibility of this subcommittee. The duties involved here are presentations to local clubs, newspaper and TV coverage, and the creation of a positive image for the overall committee and outdoor lab to other teachers and the community.

Subcommittee activities will vary from time to time; but when the need arises each should be ready to meet the challenge. Other sub-committees may also be needed at times.

Summary

Remember, an active committee is a must to ensure the success of the outdoor lab. A committee reduces the workload placed on each person. The committee should have people from various backgrounds and possess qualities needed to complete the task. Subcommittees should be organized to spread the workload even further and to utilize people with special backgrounds. The committee will provide leadership and direction for the entire school and the outdoor lab.



OUTDOOR LAB COMMITTEE WORKSHEET

Committee Chairperson

Name _____
 Address _____

 Phone _____
 Title _____
 Special Interests _____

 Sub-committee Role _____

Committee Vice-Chairperson

Name _____
 Address _____

 Phone _____
 Title _____
 Special Interests _____

 Sub-committee Role _____

Committee Member

Name _____
 Address _____

 Phone _____
 Title _____
 Special Interest _____

 Sub-committee Role _____

Committee Member

Name _____
 Address _____

 Phone _____
 Title _____
 Special Interest _____

 Sub-committee Role _____

Committee Member

Name _____
 Address _____

 Phone _____
 Title _____
 Special Interest _____

 Sub-committee Role _____

Committee Member

Name _____
 Address _____

 Phone _____
 Title _____
 Special Interest _____

 Sub-committee Role _____

Committee Member

Name _____
 Address _____

 Phone _____
 Title _____
 Special Interest _____

 Sub-committee Role _____

Committee Member

Name _____
 Address _____

 Phone _____
 Title _____
 Special Interest _____

 Sub-committee Role _____



PROMOTION AND FUNDRAISING

Working With the Media

It is important that your committee provide the media with news releases about outdoor lab developments and special projects. This will help your committee gain public support and encouragement, and can extend awareness and appreciation of environmental issues in the community. Don't forget to publicize your activities in a school newsletter, slide show, hallway display and other means within your own local school community of teachers, parents and students.

It is suggested that at least two people on the outdoor lab committee be responsible for media and public relations. Here are some suggested guidelines:

1. Make parent-teacher organizations aware of proposed projects and get them involved monetarily and physically with the projects.
2. Send home flyers with children explaining proposed projects and ask for parent involvement.
3. Send flyers or call/visit adjacent landowners to school grounds to explain projects and their purposes.
4. Contact local media about being at your all day work/construction sessions or big planting days with children. Prepare and send a media information packet in advance.
5. On days you expect the media, have a fact sheet explaining what you are doing that day and why. Be specific about the features of the outdoor classroom and try to have children working, if possible.
6. Make yourself available for service group luncheon or meeting presentations

Funding Sources for Outdoor Labs

Very seldom do we get something for nothing. This is also true for outdoor labs. The costs involved with outdoor labs vary from a few dollars to several thousand dollars depending upon the desires of the outdoor lab committee. Cost should not be a determining factor when planning your outdoor lab.

Your outdoor lab committee should have a subcommittee to oversee funding of the outdoor lab. The subcommittee will need to be creative and confident when pursuing funds for the outdoor lab. While grant writing skills are certainly helpful, the most important ingredients for successful fundraising are persistence and a clearly expressed vision.

Suggestions for Pursuing Funds

To gather funds for an outdoor lab you will need some type of wish list of items for your outdoor lab. This list of items will result in forming a budget and timetable. Once this has been developed you are ready to begin a fund drive. One suggestion when approaching organizations or individuals for money is that most are competing with each other for recognition. If you can secure funds from one group, you have cleared a major obstacle. When you approach other sources of funds let them know you have committed funds and identify who has given them. The competition between groups may swing the decision in your favor. It will pay you to start fund raising with a "sure thing" such as a group or individual that has previously given to the school. Remember to tell them exactly what you want, how much it costs and how you will use it to benefit the students. You may be more successful if you ask for portions of the funds instead of asking for everything from one source.

A List of Possible Funding Sources

- School PTA
- Individual School's Budget
- School Corporation Board
- Local Service Clubs and Organizations
- Local Conservation Clubs
- Local Businesses
- Corporations
- Fundraising Dinners
- Local Foundations
- Soil and Water Conservation District
- County Farm Bureau Group
- State of Indiana Rural Endowment Program
(Contact Indiana Department of Commerce)
- Bake Sales
- Raffles
- Collect Recyclable Products

When a group gives you funds, give them some publicity whether it be a sign in the lab, newspaper article or just word of mouth. They will appreciate and remember it next time you ask for something.



REFERENCE MATERIALS

Curriculum/Activities

1. The Young Naturalist by Andrew Mitchell
2. The Berenstain Bears Nature Guide by Stan and Jan Berenstain
3. Tips and Tricks in Outdoor Education by Malcolm Swan
4. Sharing Nature With Children by Joseph Cornell
5. Growing Up Green by Skelsey and Huckaby
6. Dover Coloring Book Series by Dover Publications, NY,NY
7. Nature Scope by the National Wildlife Federation
8. Project Learning Tree, Project WILD and Project WET, contact the Indiana Department of Natural Resources
9. Outdoor Areas As Learning Laboratories: A CESI Sourcebook compiled by Alan J. McCormack, Eric Clearinghouse for Science, Mathematics and Environmental Education, Ohio State University College of Education
10. Greening School Grounds: Creating Habitats for Learning, edited by Tim Grand and Gail Littlejohn, Green Teacher, Lewiston, NY

References:

1. Fruit & Twig Key by William Harlow
2. Garden Pools by Sunset Books
3. Find the Constellations by H. A. Rey
4. Reading the Woods by Vinson Brown
5. Reading the Outdoors At Night by Vinson Brown
6. A Guide To Nature In Winter by Stokes
7. The Reasons For Seasons by Linda Allison
8. Golden Field Guide Series
9. Finder Guides by Nature Study Guild, Box 972, Berkley, CA 94701
10. Prairie Primer by Stan Nichols and Lynn Entine, University of Wisconsin, Publ. -6-2736
11. Peterson Field Guide Series
12. Brooklyn Botanical Garden Handbook Series, 1000 Washington Avenue, Brooklyn, NY 11225
13. Woodworking for Wildlife, Minnesota DNR, 500 Lafayette Road, St. Paul, MN 55155
14. Landscaping for Wildlife, Minnesota DNR, 500 Lafayette Road, St. Paul, MN 55155

Resources:

1. Bullfrog Films, Inc., Aley, PA 19547
2. Outdoor Products and Programs, P. O. Box 1492, Oxford, MS 38655
3. Nasco Supply Co., 901 Janesville Avenue, Fort Atkinson, WI 53538
4. Schoolmasters Science Supply, 745 State Circle, Box 1941, Ann Arbor, MI 48106
5. American Camping Association Catalog and Book Store, Bradford Woods, Martinsville, IN 46151
6. Forestry Suppliers, 205 West Rankin, P. O. Box 8397, Jackson, MS 39204-0397



PLANT MATERIAL LISTS

WINDBREAKS AND SCREENS:

EVERGREEN:

White Pine
Red Pine
Norway Spruce
Arborvitae

CLIPPED HEDGES:

Corneliancherry Dogwood
Washington Hawthorn
American Hornbeam
Canada Hemlock
Carolina Hemlock
Hedge Maple

WILDLIFE PLANTS:

Dogwoods
Mountain Ash
Firethorn
Russian Olive
Sunflower
Elderberry
Highbush Cranberry
Blueberry
Crabapples
Serviceberry

SHRUBS FOR WET AREAS:

Serviceberry
Button Bush
Shrub Dogwood
American Cranberry
Willow
Black Alder

TREES FOR FALL COLOR:

Sweet Gum (crimson to purple)
Serviceberry (orange to red)
Norway Maple (orange)
Ash (yellow to purple)
Black Gum (bright red)
Cherry (yellow)
Dogwood (crimson)
Eastern Redbud (bronze to yellow)
Purple Leaf Plum (purple)
Red or Black Oak (red to brown)
Tulip Tree (yellow)
Sugar Maple (orange)

DECIDUOUS:

Lilac
Russian Olive
Highbush Cranberry
Viburnum
Privet
Bottlebrush Horse Chestnut

SENSORY PLANTS:

Saucer Magnolia
Common Witch-hazel
Wooley Lamb's Ear
Chives
Anise Hysop
Lemon Balm
Lavender
Lemon and Purple Basil
Scented Geraniums
Sage
Pineapple Sage

SHRUBS FOR DRY AREAS:

Barberry
Witch-hazel
Nine Bark
Nannyberry
Yucca

ACCENT TREES AND SHRUBS:

Snowdrift Crabapple
Japanese Maple
Common Smoketree
Inkberry Holly
Ginkgo
Golden Rain Tree
Saucer Magnolia
Rhododendron P. J.M. Hybrid
Star Magnolia

VINE:

Trumpet Creeper
Pink Japanese Wisteria
Chinese Wisteria
Oriental Bittersweet
October Clematis
English Ivy
Grape
Henryi Honeysuckle



PLANT MATERIAL LISTS

GROUND COVERS:

Creeping Cotoneaster
Wintercreeper Euonymus
Blue Rug Creeping Juniper
Cranberry Cotoneaster
Japanese Spurge
Creeping Blue Phlox
Lamb's Ear
Hostas

THORNY SHRUBS (for barrier):

Russian Olive
Firethorn
Black Raspberry
Trifoliate Orange
Flowering Quince
Oregon Grape Holly
Blackthorn

TREES WITH INTERESTING OR COLORFUL BARK (for winter interest):

American Beech
Blue Beech
Hackberry
Shagbark Hickory
Paper Birch
River Birch
Cherry
Yellow - Twig Dogwood

COLORFUL FRUIT SHRUBS:

Cotoneaster
Firethorn (red)
Evergreen Privet (blue - black)
Snowberry (white)
Wintercreeper (orange)
Koreanspice Viburnum (red - black)

SHRUBS FOR WET AREAS:

Serviceberry
Button Bush
Shrub Dogwood
American Cranberry
Willow

NATIVE PLANTS:

These groups and organizations offer a wealth of information about native plants:

Indiana Native Plant and Wildflower Society
3134 Greenbriar Lane
Nashville, IN 47448-8279
<http://www.inpaws.org>

IDNR, Division of Nature Preserves
402 W. Washington Street, W267
Indianapolis, IN 46204
317/232-4052

The Nature Conservancy, Indiana Chapter
West 38th Street
Indianapolis, IN 46208-4103
317/923-7547

Wild Ones - Natural Landscapers, Ltd.
<http://www.epa.gov/greenacres>

Lady Bird Johnson Wildflower Center
<http://www.wildflower.org>

Recommended Reading:

The Gardener's Encyclopedia of Wildflowers
by C. Colston Burrell; Rodale Press, 1997

Go Native! Gardening with Native Plants and Wildflowers in the Lower Midwest
by Carolyn Harstad; Indiana University Press, 1999

Landscaping with Native Trees
by Guy Sternberg; Chapters Pub Ltd., 1996

The Natural Habitat Garden
by Ken Druse; Clarkson Potter, 1994



MAINTENANCE

A good maintenance program is essential to both the initial and long term success of your outdoor classroom. It is important that at least two people from the outdoor classroom committee have primary responsibility of designing a maintenance plan for various features of the outdoor classroom. Be sure to involve a key member of your school's building and grounds staff in your maintenance plan. Each plan should list what the short and long term maintenance requirements are and who will be responsible for each. Unnecessary maintenance can be kept at a minimum by keeping development or special project plans simple. If it can't be easily maintained, you may want to reconsider developing it.

JANUARY

- Keep all bird feeders full
- Prune deciduous trees and shrubs

FEBRUARY

- Keep all bird feeders full
- Burn prairie - Late February, March, and April before green-up of plants

MARCH

- Clean out bird nest boxes of unwanted birds
- Check all structures for winter damage
- Keep all bird feeders full

APRIL

- Reinstall pump in pond
- Check around pond for damage or areas where liner is exposed
- Clean up plant beds
- Apply herbicide treatments around trees or in areas where trees are to be planted
- Fertilize trees and shrubs
- Plant trees and shrubs
- Take down snow fence
- Spray fruit trees as needed; follow label directions

MAY

- Till perch 'n' plot, horticulture plot, any other areas as needed
- Plant wildlife food plot, other herbaceous wildlife cover
- Plant horticulture and other plots
- Spray fruit trees as needed; follow label directions

JUNE

- Weed horticulture and other plots
- Set out insect traps
- Spray fruit trees as needed; follow label directions
- Prune pines

JULY

- Repaint, restain or repair all wooden structures as needed
- Check insect traps
- Weed horticulture and other plots

AUGUST

- Check insect traps
- Weed horticulture and other plots

SEPTEMBER

- Check insect traps
- Weed horticulture and other plots

OCTOBER

- Pull up herb garden annuals, horticulture plot after frost
- Order trees for next spring
- Thin bulbs, corms and tubers
- Take down insect traps

NOVEMBER

- Remove pump from pond
- Begin filling bird feeders
- Prune deciduous trees and shrubs
- Put up snow fence

DECEMBER

- Keep all bird feeders full
- Prune deciduous trees and shrubs

GENERAL MAINTENANCE AS NEEDED:

- Trail construction/repair
- Turn compost pile
- Mow grass
- Check water level in small ponds and add water as needed



FEATURES

The following information is intended primarily as an idea list. While some specifications for construction are provided, most are not. Such detail would make this publication too lengthy, and for many features, there are a number of “right” ways to construct them. Consult with local natural resource or construction specialists when planning features.

Animal Tracking Plot

Even an urban area is frequented by many species of wildlife each day. Birds, mice, squirrels, rabbits, opossum, raccoons and even deer can find themselves at home in the city. Whether your school is located in a rural or urban area, an animal tracking plot can yield some interesting tracks to study. An area about 3 feet by 3 feet or larger is all that is needed to create this feature. The area should be cleared of all grass or other vegetation and filled with clay.

Permanent tracks for comparison can be provided by pouring a 3 feet by 3 feet concrete pad next to the tracking plot. Before the concrete hardens, make various tracks in the concrete using either rubber or plaster casts of tracks. These can be purchased through biological supply companies.

Food scraps, grain or other “bait” should then be placed near the plot regularly to attract wildlife to the area. The night before your students are to study the tracks, moisten the clay so it is soft enough to leave a clear impression by the animals. Students may be surprised at the variety of “critters” right in their own back yard.



Arboretum

Did you ever want to take your class to a woods where you would be able to find a wide variety of tree species? Plant an arboretum now and in a few years you will have such a woods right on your school grounds!

An arboretum is simply a woods where many different species of trees occur or have been planted. Once planted, the area can be left to grow up to look more like a natural woods, or can be mowed and kept as more of a formal arboretum. In either case, signs should be put up throughout the area identifying each tree, its characteristics and uses.

To get your arboretum established, the area where trees are to be planted should be cleared mechanically or with herbicide to reduce competition from other vegetation. The planting area should be laid out just as any tree plantation, allowing each tree adequate space for growth. Seedlings may be purchased at a nominal cost through the Indiana Division of Forestry’s state nurseries. Planning assistance for your tree plantation can be obtained from your District Forester.

Archaeological Dig Site

This is an area where students can learn the techniques used in archaeological digs, while unearthing “planted” artifacts. Such an activity can also be tied into historical studies and soils investigations. While an archaeological dig site is intended as a way of introducing students to the fascinating study of archaeology, it must impress upon students that actual sites of historical or archaeological significance (sites having artifacts 50 years of age or older) and all prehistoric sites are protected by law and must not be disturbed. For more information, contact the Indiana DNR—Division of Historic Preservation and Archaeology.

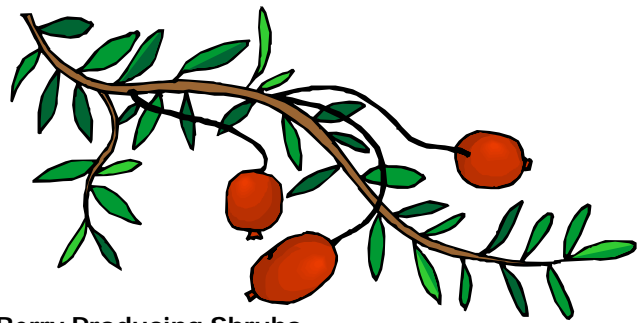

Berry Producing Shrubs

For quick growth, beautiful color, wildlife food and cover, erosion control and general outdoor studies, it’s hard to beat berry producing shrubs.

Many shrubs, when planted as seedlings will quickly obtain a height of six to eight feet in four to five years. Due to their smaller size at maturity, shrubs can be spaced closer together than trees. Six feet apart is usually adequate.

Purple willow, amur honeysuckle, shrub dogwood, highbush cranberry and japonica lespedeza are examples of shrubs suitable for outdoor classroom planting. Small trees such as flowering crabapple, flowering dogwood, Washington hawthorne and redbud are also recommended. Before planting be sure to know what kind of soil and other limitations the shrub species may have. Plant in clumps or rows preferably near your food plots and herbaceous plantings of grasses and legumes. Inexpensive tree and shrub seedlings are available from the Indiana Department of Natural Resources, Division of Forestry. Order blanks and price lists can be obtained by calling your local district forester or soil and water conservation district office.

Bird Blind

When observing birds near a feeder or around a pond or marsh, wouldn’t it be nice to be invisible? Perhaps the next best thing is to be hidden behind a bird blind. A simple wood frame structure covered with chicken wire serves as a good foundation to be covered with leaves and other natural debris, leaving a small area open for observation. Such a frame can be permanent or made with hinges to be folded and easily moved.



FEATURES

Bird Feeders

Attracting songbirds to the school grounds is easily accomplished by establishing feeding stations around the school. Cardinals, song sparrows, chickadees, nuthatches and goldfinches are among the colorful visitors that frequent such wildlife diners. There are many different types of feeders commercially available, although it is easy to construct your own. If you establish feeders on your school site, be sure they are kept supplied with food.

Bulbs, Corms and Tubers

Fall planting of bulbs, corms or tubers will result in many years of colorful spring flowers. Students can gain practical landscaping experience by planning and managing their bulb garden, and can improve math skills by calculating the rate at which their bulbs multiply each year.

Butterfly Garden

Colorful surroundings attract colorful visitors to outdoor labs. Plantings of columbine, foxglove, asters, primrose, daisies and other bright wildflowers will provide your students excellent habitat for observing or collecting many species of butterflies and moths.



Compost Pile

Any school having a garden or horticulture plot should also consider developing a compost pile. Leaves, grass clippings, kitchen scraps and other organic debris can be turned into nutrient-rich soil in a relatively short time. Commercial compost bins can be purchased for a modest cost, or a compost area can be constructed for even less.

Creek

A creek can be a good area for students to observe and study many aquatic plants and animals. Throughout the school year, students can measure and record stream flow. They can also test water quality for pH, temperature, dissolved oxygen, sediment load before and after storms, etc. If within the school budget, obtain some water testing kits.

Most creeks meander due to silt and sediment bars that are a result of soil erosion within the creek's watershed. This results in streambank erosion as well. Students should determine the size of the creek's watershed and trace its course to larger watersheds.

Plant berry producing shrubs and grain food plots parallel to the creek channel. Amur honeysuckle, purple willow, shrub dogwood, japonica lespedeza and the highbush cranberry are possible shrub plantings. Some brush piles and nesting boxes along the bank would also attract more wildlife to the creek.



Dinosaur Study Area

Given a blacktop parking lot and a piece of chalk, students can begin learning about dinosaurs by drawing the life-sized outline of one. More detailed or elaborate studies can be made by building life-sized or scale models of dinosaurs using a wood and screen skeleton and plaster, paper mache or gunnite exterior. Full scale nests of eggs and footprints can be made, as well as a "Trail of Time" around the school grounds. If one foot equals 160,000 years, it would be about 1,500 feet back to the dawn of the dinosaurs, 400 feet to their extinction, 30 feet to the first humans and $\frac{3}{4}$ of an inch to the end of the most recent Ice Age (which was 10,000 years ago!)

Existing Timber Stand

A school woodlot can be used for studies in species identification, population, watershed, forestry, wildlife and many other educational opportunities. Many school woodlots have not been actively managed, so are overstocked and hampered with vines. They are in need of timber stand improvement (TSI). TSI is a term used to identify various management practices used to improve vigor, stocking, composition, productivity and quality of forest stands. Talk to a forester about how TSI could be applied to your woods.



FEATURES

Erosion Control Demonstration Area

Our country has lost an alarming amount of topsoil because of erosion by wind and water. To demonstrate the effects of erosion and some measures used to control it, first select a site on your school grounds with a moderate slope. This can be an area as small as about 10 feet wide. If a suitable slope does not exist, one can be created by mounding and compacting soil in a hill about 3 to 4 feet high.

Next, strip all grass and other vegetation from the area, leaving only bare soil exposed. Divide the area into three equal parts and leave one portion alone, cover another section with rip rap (large stone) and plant a ground cover such as crown vetch or grass in the final section. Now students can study the effects of erosion on the bare soil, while seeing how effective the control measures are on halting or minimizing erosion.

To quantify how much erosion is taking place in each section; a collection pan can be installed at the base of each section to funnel runoff water and sediment into a container. The amount of sediment collected in each container can then be measured.

Fence Row

An old woody fence row is one of the best outdoor classrooms you can find. Often a fence row is an undisturbed area. In other words, it is unlikely that a plow or dozer blade has ever turned its soil. This makes an old fence row a valuable soil study area. It's also a good place to find discarded "junk" from years gone by, leading to historical interpretation.

Students should study the types of vegetation and animals they find in the fence row. Are there any trees that have actually grown around the fence wire? A fence row is a good wildlife "travel lane" and is a fine location to place nesting boxes, food plots, brushpiles and shrub

Fossil Path

Establishing a fossil path gives students the opportunity to study forms of life no longer existing. Students are fascinated with fossils and how they are formed. Such a feature can lead to studies of history, exercises in language arts or art projects dealing with natural shapes and patterns.

Grasses Plots

Have you ever tried to establish grass cover in an area to match an existing lawn, only to find that it is a different color or grows at a different rate? There are so many varieties of grass seed on the market, each with its own growth characteristics. Establishing a plot of several different grass types allows students to learn what the different grasses look like and where each is best used.

Groundwater Monitoring Hole

This will provide students with an opportunity to see how the groundwater table fluctuates throughout the year. If recorded on a regular basis, a graph can be charted to show the monthly and seasonal levels of fluctuation. If your school site has more than one soil type, your students will be able to compare their findings for each soil. Your county soil survey (available free through your county USDA Natural Resources Conservation Service) will indicate the location of these soils and their expected water tables.

To make a groundwater monitoring hole, use post hole diggers or an auger and dig a hole five to six feet deep. Take a piece of PVC pipe and drill numerous one-eighth inch holes in it. Place the pipe in the hole to prevent the soil from caving in, and cap the top of the pipe with a PVC cap. Use a calibrated stick to take the measurements of the groundwater level.

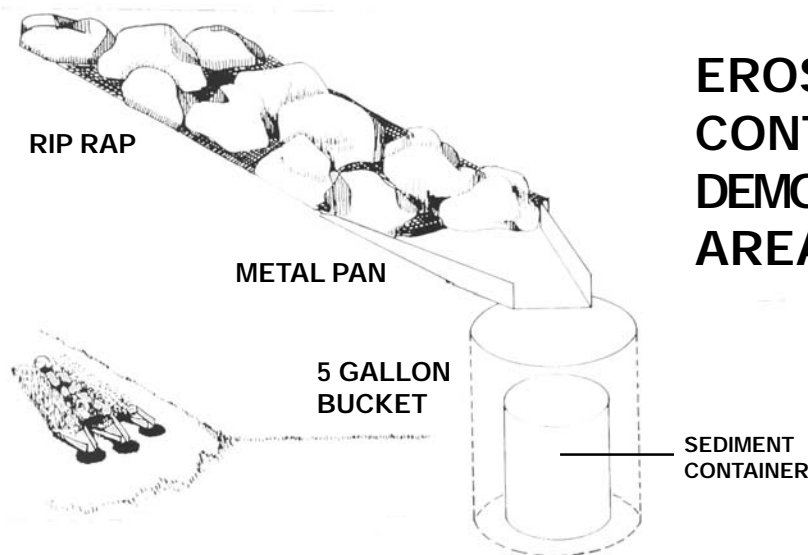

EROSION CONTROL DEMONSTRATION AREA



FEATURES

Herb Garden

A small area of the school grounds can be designated as an herb garden. This area can be located within a school courtyard, along a sidewalk next to the school building or just about anywhere there is a little space and sunlight. Herbs used for cooking and those with alleged medicinal qualities can be grown for study.

Herbaceous Wildlife Plantings

Herbaceous cover plantings of legumes such as sweet clover, red clover, alfalfa, and grasses such as orchardgrass, timothy and bluegrass are excellent ways of attracting small wildlife to your school site.

Herbaceous plantings can be planted in strips fifteen to twenty feet wide in a fallow area of the school grounds. Strips can be spaced to alternate and allow strips of natural vegetation to grow in between.

There are many good educational reasons for planting herbaceous cover. Students will see and study more wildlife that feed and nest in the strips. Bees, butterflies, beetles and other kinds of insects will be found. Students will learn to identify and recognize characteristics of various grass and legume cover crops.

Planting requires good seedbed preparation and fertilization. Planting dates, where to obtain seed and other information may be obtained from your local soil and water conservation district office.

Horticulture Demonstration and Test Plots

Measure a grid of small 10' x 10' plots. These plots can be used for various agricultural crop demonstrations, ground covers, grasses, etc. The plots can also be used for chemical testing, water testing, erosion studies, etc.

Native American Theme Area

A courtyard or little nook somewhere on the school grounds can easily be developed into an Indian study area. Indian corn, sweet corn, gourds and wildflowers can be cultivated. A fire pit and even a small wigwam might be constructed on the site. If flint is available in your area, arrowheads or other tools could be fashioned and used by students (following all safety precautions, of course).

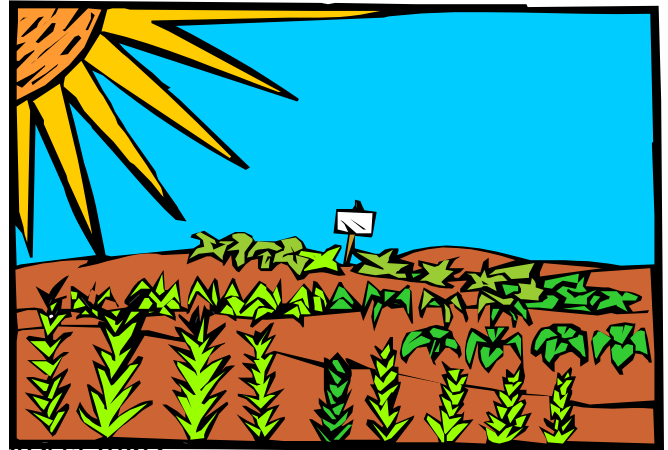
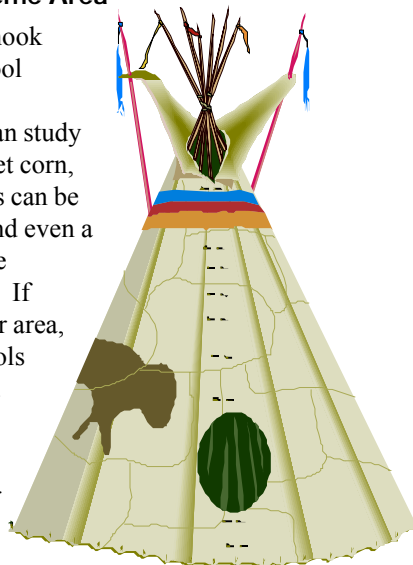

It seems the only time we think about insects is when they are bothering us. But the insect kingdom is a fascinating, seemingly endless, one. So that students might learn more about these interesting creatures, insect traps can be used to collect them. Depending upon the types of insects to be collected, traps can range from a mashed banana placed in a jar to a commercially purchased insect trap containing a sex pheromone to attract a specific insect from great distances. In addition to learning about the body structure and habits of the insects collected, students can also develop math skills by estimating local populations of a given insect.

Lath Structure

Growing shade-loving plants can be a problem if your school was built on former crop land and the nearest shade tree is in the next county. A simple way to solve this problem is to construct a lath structure. Using lath (strips of wood about ¼ inch thick and 1 to 2 inches wide) attached to a support frame, partial shade can be given to plants. An alternative to nailing lath to a support is to lay snow fencing over the support frame.

Marsh

Does your school have any wet areas on the school grounds? Most school sites do have a few. These poorly drained areas can be very difficult for maintenance crews to mow and nearly useless as a playground or athletic field. These troublesome wet spots are often very capable of being developed into nature's most productive wildlife and outdoor learning area: a marsh.

If properly developed, a marsh should have 25 percent of its area excavated to a depth of about three feet and the remaining 75 percent less than three feet deep. This will encourage growth of cattails, bulrushes, sedges, reeds, arrowhead and many other aquatic plants. Wildlife biologists also recommend planting wildlife food plants such as millet, buckwheat, grain sorghum or corn. Shrub dogwood, amur honeysuckle and purple willow are good wildlife shrubs to plant around your marsh.



FEATURES

Milled Sawlog

What happens to a log after it leaves the woods? How do we end up with lumber in the dimensions of 2" by 4" or 2" by 6"? If you have a sawmill near your community, see if they might be willing to saw a small log into lumber, then tie it back together and loan or donate it to your school. The result shows very graphically how dimensional lumber comes from a log.

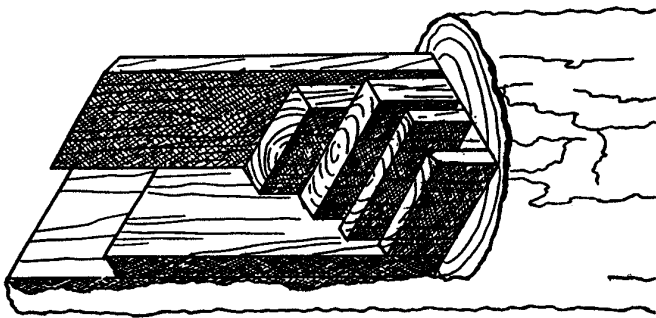

Nature's "Swap Shop"

A small area can be established where students are encouraged to donate interesting items of nature (galls, bones, rocks, etc.) and in turn, may take home any items that capture their interest. Ideally each student making a withdrawal will also make a donation; realistically, the supply may have to be replenished periodically. Either way, the purpose of the swap shop has been served if the student's curiosity and interest are stimulated. This feature may be located indoors or outdoors, and could even be made as a portable feature.

Nesting Boxes

Artificial nesting boxes can be built by students and placed in various locations on your school grounds. This will attract more wildlife, and allow students to observe and study nesting characteristics of small animals.

A wildlife biologist can provide specifications and information on what kinds of nesting boxes to build for your area. Wooded fence rows, grassy meadows, forested areas and the banks of ponds and creeks are good locations for nesting boxes. Hollow trees, old fence posts and burrows in the ground can be existing natural nesting sites. Old, dead trees (called "den trees") not in danger of falling on a structure are good to leave for wildlife nesting.

When considering nesting boxes, keep other animals besides birds in mind. Nesting structures for squirrels, bats and ground nesting mammals are also easily constructed.

Orchard

Here is an opportunity to teach students about Johnny Appleseed, fruit tree management and cooking skills, while possibly raising money for the outdoor lab. An orchard also provides beautiful, fragrant blossoms in the spring. With many dwarf varieties of fruit trees available, an orchard needn't require a great deal of land. It will require a great deal of year-round work, however. So if you plan to develop an orchard, be sure to make provisions for seasonal pruning, spraying and harvesting.

Ornamental Flower Beds

Whether in an urban or rural environment, most homeowners appreciate the beauty, fragrance and color that flower beds add to their home landscape. Students should have the opportunity to learn how to cultivate and care for ornamental plants, including flowers and shrubs. Establishing an ornamental flower bed affords students this opportunity, while beautifying the school grounds. Students can feel a real sense of accomplishment and pride in their school grounds. If there are areas along the building that sunlight seldom reaches, a shade tolerant flower bed can be established.

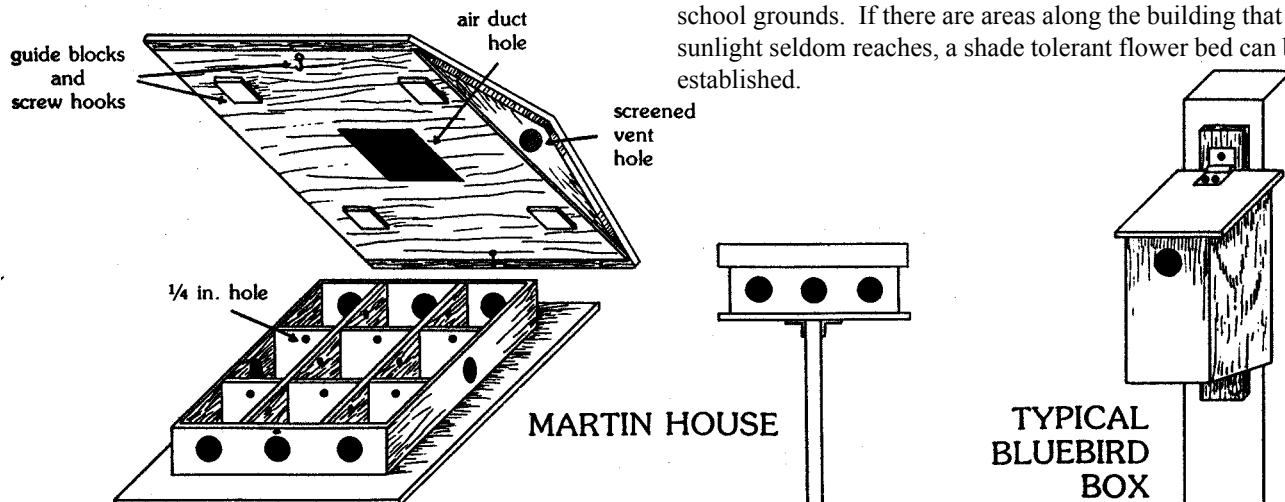



FEATURES

Outdoor Seating Area

A seating area may range from a nice amphitheater or shelter house to a simple circle of telephone poles or railroad ties. One of the simplest and least expensive benches is made by erecting two 4" by 4" treated posts and placing a treated (not creosoted) 2" x 10" board across the top and a couple of braces as shown below.

Perch 'n' Plant

Have you ever wondered how so many trees start growing along fences? This simple feature allows students the opportunity to see a fencerow develop and learn how the trees got there.

Clear all vegetation on a strip of land about 3 feet wide and at least 10 feet long. (You may have better results if the area is also worked up with a rototiller.) Erect a fence post at each end and stretch a cable between the posts. As birds begin perching on the cable, their droppings will be "planting" many different types of seeds. Students may even wish to keep a log of what species of birds they have observed on the cable and what types of plants begin growing under it, to learn what foods the birds prefer.

Pond

A pond on the school site can provide some excellent opportunities for students to observe and study aquatic plants and animals. Ponds also provide students with firsthand experience in managing water resource problems and solutions.

If the pond is $\frac{1}{2}$ acre or larger and has a minimum depth of 8 feet over 25 percent of the area or a minimum of 6 feet over 50 percent of the area, it can probably support a healthy fish population of bluegill, largemouth bass and channel catfish. For ponds less than $\frac{1}{2}$ acre, biologists suggest stocking channel catfish fingerlings only at 500 to 1,000 per acre. A soil conservationist or fishery biologist can advise how to properly stock and manage your pond.

Transplant a variety of aquatic plants around your shoreline for more diversity. Wildlife biologists also recommend planting a variety of trees, shrubs, legumes and grasses around the pond area to attract more wildlife.

If your school does not have a pond but is interested in constructing one, consult with your local soil conservationist. He or she can investigate the feasibility of a pond site on your school grounds. Keep in mind that a pond for learning can be as small as a shallow reflecting pool, teeming with live microscopic specimens. If a deeper pond is desired, the school's liability insurance should be checked to see what additional precautions are needed.



Prairie Plot

At one time, prairies covered portions of Indiana. While remnants of these prairies still exist in the state, relatively few people have the opportunity to study these areas or even recognize prairie plants. A small prairie area can be established by clearing all vegetation from the site and planting prairie seed. It takes many prairie species more than one year to germinate, so be patient. Each year the plot should be cleared, preferably by burning if safe to do so. If not, mowing or clearing by hand should suffice.

Road

A road or parking lot is a good place for students to study how surface water runoff leaves pavement. Students should learn why drain culverts are placed in certain locations (low points) and why culvert sizes are often in different diameters.

Is there any erosion of soil where water leaves the hard surfaces? After studying the drainage, examine how natural resources were used to make any paved surfaces. Are there any cracks caused by freezing and thawing, or shrinking and swelling of the soil as it becomes wet and dry?



FEATURES

Rock Pile, Geological Studies

Start a rock pile of large rocks that are too heavy to be thrown. Have students bring in samples from vacations or around their homes. Place the rocks in a pile along a fence row, creek bank or other area out of the way of mowers. Aside from studying geology, rocks can be used in math to study weights, mass, volume and geometric shapes, and can be used in art for varying textures, colors and shapes.

Sensory Discovery Area

This is an excellent area for primary students, allowing them to explore with all of their senses. Many plants with strong fragrances, brilliant colors or unusual textures can be established in this area. Other natural objects such as rocks, tree bark, seed pods, or furs can be used to expand sensory awareness. Using herbs and other edible plants, students can safely taste some of Mother Nature's offerings.

Shelter

Not many school outdoor labs have the luxury of a building in which to hold class. Aside from providing shelter from inclement weather, a building also provides a place for displays and other educational materials. Schools have made use of many different types of structures including log cabins, open picnic shelters, old barns, maple sugar shacks and greenhouses. If a shelter is not financially feasible, a small storage building should be considered for storing tools or other materials to be used in the outdoor lab.



Signs

At first glance, an outdoor lab sometimes looks like a hodge-podge of strange structures and random plantings. When visitors come to the school, a much more favorable impression would be made if they could read interpretive information about the outdoor lab and its features. Small signs explaining each part of the outdoor lab also helps familiarize students and new teachers to the lab and its purpose. A large sign near an entrance to the lab can provide general information about the lab, as well as designating the area for educational use.

Snow Fence Demonstration

What can you do in an outdoor lab when students return to school after a snow day? If you have some snow fences erected, students can observe the effects that the fence had on drifting and measure snow depth at various distances from the fence. Snow fence is used in several states extensively to limit drifting on highways. Blowing snow will hit the fence and be deposited on the other side, thus positioning the drift in a limited area. After some experimentation, students may find areas around the school drive or parking lot that would benefit by some seasonal fencing.

Soil Studies

“Dirt” is what you sweep off the floor or wash from your hands. “Soil” is a precious natural resource. This difference should be recognized by your students before any other form of soil study is undertaken.

Students should become familiar with your county soil survey. Using the information in the survey, determine the location and various characteristics of the soils found on your school grounds. A soil testing area on each of the soil types should be established. Students should carefully examine the soil, layer by layer, starting at the surface and observing the types of vegetation growing there.

There are many good soil testing kits available for purchase from school supply catalogs. Try to obtain some of these. A very useful booklet titled “Teaching Soil and Water Conservation, A Classroom and Field Guide,” – PA 341 is available from your county soil and water conservation district office.

Solar/Wind Energy Demonstration

As human population continues to expand, developing creative sources of energy is more critical. Setting up small scale demonstrations of solar and wind energy generation will make students aware of alternatives to fossil fuels, and perhaps even generate enough energy to power other features in the outdoor lab.



FEATURES

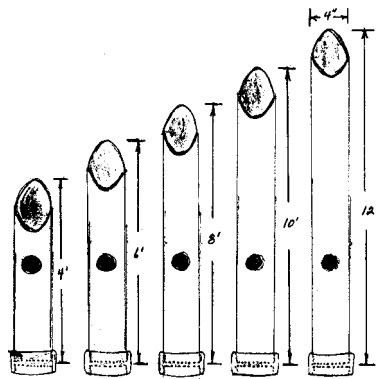

Sound Tubes

An outdoor lab can be used for far more than the study of nature. For example, students can investigate the nature of sound by creating sound tubes. These are constructed by taking several varying lengths of PVC pipe that are each approximately 4 inches in diameter, cutting one end of each at a 45 degree angle, and installing them vertically in the ground with the 45 degree cut end at the top. A 3-inch hole is cut in each pipe about 3 feet above the ground. As wind blows across the tops of these pipes, each will produce a sound, the tone of which will vary with the length of pipe. Students can place their ears to the hole of each pipe to hear the sound. Science teachers can use this feature to discuss the creation of sound and why the pipe's length affects the sound tone. Music teachers can relate these sound tubes to the many musical instruments that operate on the principle of air passing across varying lengths of tube to create sound.

Storage Building

While a storage building is not necessary for all outdoor labs, it can certainly save time if the lab is located some distance from the school building. The building need not be large – just a dry, secure place to store shovels, hoes, weather instruments, soil probes, dip nets and any other items frequently used.

Succession Areas

By not mowing selected areas of your school site, a greater diversity of plants and plant maturity will occur. This process of gradual (and predictable) replacement of one community of plants and animals by another is referred to as succession. Students can observe and record the various successional stages that will occur. A succession plot should be regularly monitored and any noxious weeds eliminated.

Sundial

Very ornate sundials can be purchased, or students can make their own using simple materials like cardboard or wood. Either way, a sundial opens the door to studying in earth's movements, angles and historical aspects of keeping time.

Time Capsule

It's fun to look at mementos from the past, particularly when those items have some personal significance. Clues to what was news, what was popular and who you were can be rediscovered when placed in a time capsule to be opened years later. For example, kindergarten students might place news clippings, school photographs, popular toys, audio or video tapes and other treasures in a time capsule to be opened when they graduate from elementary or high school.

Trail

An established foot trail is a good way to prevent students from trampling over tree seedlings, ground nesting animals and vegetation with low tolerance for foot traffic. Much planning is required before establishing a trail system. Topography, soil types, drainage, vegetation and obstacles are some of the consideration to be made, as well as routing the trail to all points of interest.

Trails should be surfaced with woodchips or stone to reduce soil compaction and for ease of walking. (Woodchips are often available free of charge through local electric companies.) Access over or through wet areas should be provided by constructing foot bridges and boardwalks, and slopes along the trail should be protected from erosion by using water bars, dips or retaining structures.

Any posts placed in the ground along trails should be anchored in concrete at least two feet in the ground. All wood should be chemically treated to prevent decay, and the tops of all posts should be cut off at a slant so they will shed water.

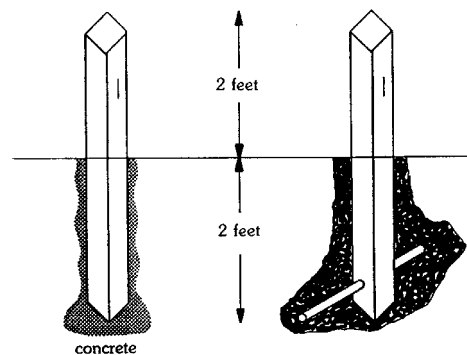

Tree Cross Sections

People record accounts of history in books or on film; Mother Nature uses trees! The cross section of a tree can tell a great deal about that tree's personal history (fires, lightning strikes, insects and diseases, competition from other trees, etc.), and can tell much about weather conditions of past years. Students can also use a tree cross section as a calendar, marking significant events in history by the rings of the tree. Comparing the tree's diameter in various years is a good way for students to visualize the tree's rate of growth.



FEATURES

Tree Plantation

Trees are renewable resources; in a very real sense, they are a crop. Tree farms or plantations are providing more and more timber to meet the wood product demands of a growing population. Tree plantations of black walnut, white oak, ash and many other species are planted for their highly prized lumber. Tree plantations of black locust are planted as “energy acres” for their excellent firewood potential. Tree plantations of Scotch and white pine are planted for Christmas trees.

Plant a tree plantation on your school grounds. Depending upon the allocated space for such a project, a school could realize considerable profits from this inexpensive investment. Christmas trees are harvestable after about seven years, black locust firewood after about fifteen and hardwood sawlog plantations after thirty years or more.

Students can learn a great deal about forest management techniques from their involvement with a tree plantation. Even if you only have a small area students could still establish a demonstration plot of various tree species for observation and study.

Tree Seedling Nursery

Planting trees on your school grounds is a great experience for children; but some of those trees are likely to die within the first few years. Establishing a small tree seedling nursery allows you to replace those trees with others of similar size. It also affords students the opportunity to learn about how to germinate tree seed, care for seedlings and transplant larger trees.

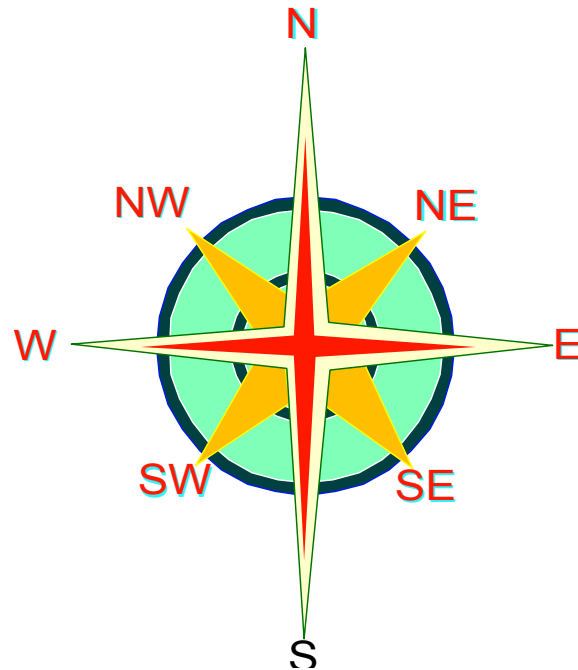

Watering Hole

Because of increased liability pressures placed on schools, it is sometimes not feasible to build a pond. Many of the same benefits of having a large pond can also be obtained by constructing a small, shallow watering hole for wildlife. This structure can be as small as a child’s wading pool and still support abundant life from aquatic plants and microorganisms to tadpoles and minnows. If located near the school building where electricity is available, a small pump can be used to create a waterfall and circulate the water.

Weather Station

Even schools with very little space can probably find room to establish a small weather station. Students can keep records of temperature, rainfall, barometric pressure, windspeed, direction, etc. Weather instruments are available through school science supply catalogs. Instrument costs will vary, and some simple instruments can be made by students. Weather stations with more sophisticated equipment should probably be fenced for protection.

Whisper Tube

Without the interference of other sounds or the dissipating effect of open space, it is amazing how far sound can travel. To demonstrate this with students, take a garden hose that is at least 50 feet in length. Insert a funnel to each end of the hose and secure them with duct tape. A student whispering in one end of the hose will be easily heard by a student listening at the other end. Allow students to experiment by connecting additional lengths of hose, or running the hose partially around the school building.



FEATURES

Wildflower Plot

Wildflowers not only add an attractive atmosphere and aroma to an area, but also can be used to produce dyes for fabric or paints. Areas of full sunlight or total shade can both be used to establish plantings of wildflowers. Wildflowers also attract many species of insect and birds for study.

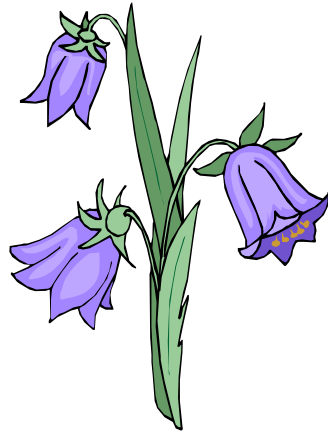

Wildlife Brushpiles

Fallen or pruned limbs and even discarded Christmas trees can all be useful building material for wildlife brushpiles. Brushpiles are like natural magnets when it comes to attracting wildlife. Piles should be at least 12 feet in diameter and 5 feet high to be effective.

Wildlife Food Plots of Grains

Planting strips of grains such as corn, sorghum, soybeans, buckwheat, rye, wheat, etc. can provide a good food and cover source for wildlife and expanded learning experiences for students.

A typical food plot would be about 10 feet wide and perhaps 100 feet in length. Plant the food plots in alternating strips or parallel to a fence row, wooded edge or creek bank. If you are planting on sloping ground, plant in contour rows.

Allow the grain to stand over the winter to provide good cover for rabbits, birds and other small animals. Plant a variety of the different grains so students will be able to observe and study them.

A food plot requires good seedbed preparation. Consult with a soil conservationist or wildlife biologist for recommended seeds, planting dates, seedbed preparation, etc.

Windbreaks of Tree and Shrub Plantings

If raw, winter blasts of cold winds blow across your school grounds, plant a living windbreak of trees and shrubs. Due to prevailing wind directions, windbreaks should be planted along north and west boundaries. There are several species of trees used for windbreak plantings, most commonly white and red pine, Norway spruce or northern white cedar. Trees should be planted on a 12' X 12' spacing, and rows of trees staggered. If spacing permits, a row of shrubs should be planted on the windward side of the windbreak. Black chokeberry, shrub dogwood, or ninebark are all excellent shrub species to use, providing fast growth and food for wildlife.

Wood Decay Test Site

Any wood will eventually decay. But some decay much faster than others, and various treatments to wood can delay decay for many years. To construct a wood decay test site, first obtain small, equally sized pieces of cedar, locust, redwood and treated and untreated pine. Mark the date on each piece, weigh each then bury them all to an equal depth. Repeat this procedure each year, keeping records of all weights. After about 5 years (possibly longer, depending on wood and ground conditions), remove the first year's samples, clean them thoroughly and place them in the sun or in an oven on a low setting until they are completely dry. Weigh all of the samples and compare with their original weights. By repeating this process each year, there will always be a set of wood samples to compare after the initial 5 years.

Woodland Clearing/Regeneration Area

Trees, like corn or soybeans, are a crop. They grow to maturity and, if left to continue growing, will eventually decline and die. The intent of forest management is to encourage the growth of tall, straight, healthy trees as quickly as possible to be harvested at maturity. Once a mature tree is removed, regeneration of new trees can begin because the mature tree is no longer taking nutrients and sunlight from surrounding saplings. This process allows for the perpetuation of a healthy, productive forest.

If your school has a woods, consider clearing groups of trees in a quarter to half-acre area. Such a clearing will allow for the regeneration of many beneficial species of trees, as well as providing wildlife with improved herbaceous food and cover.



EROSION CONTROL TEMP. PLOT:

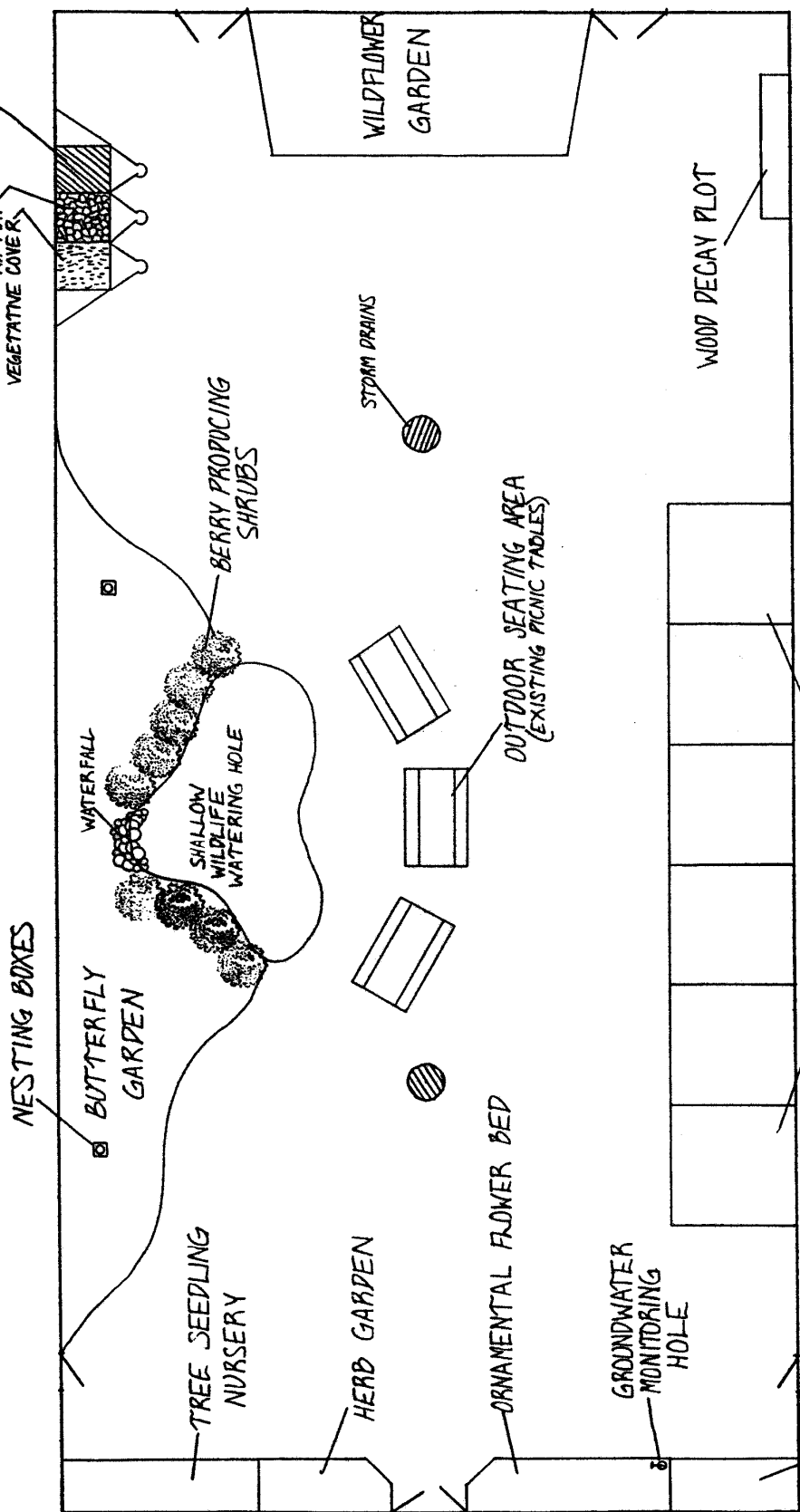

Enclosed Courtyard

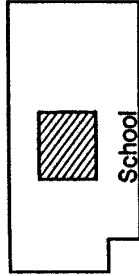
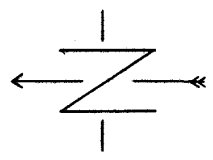

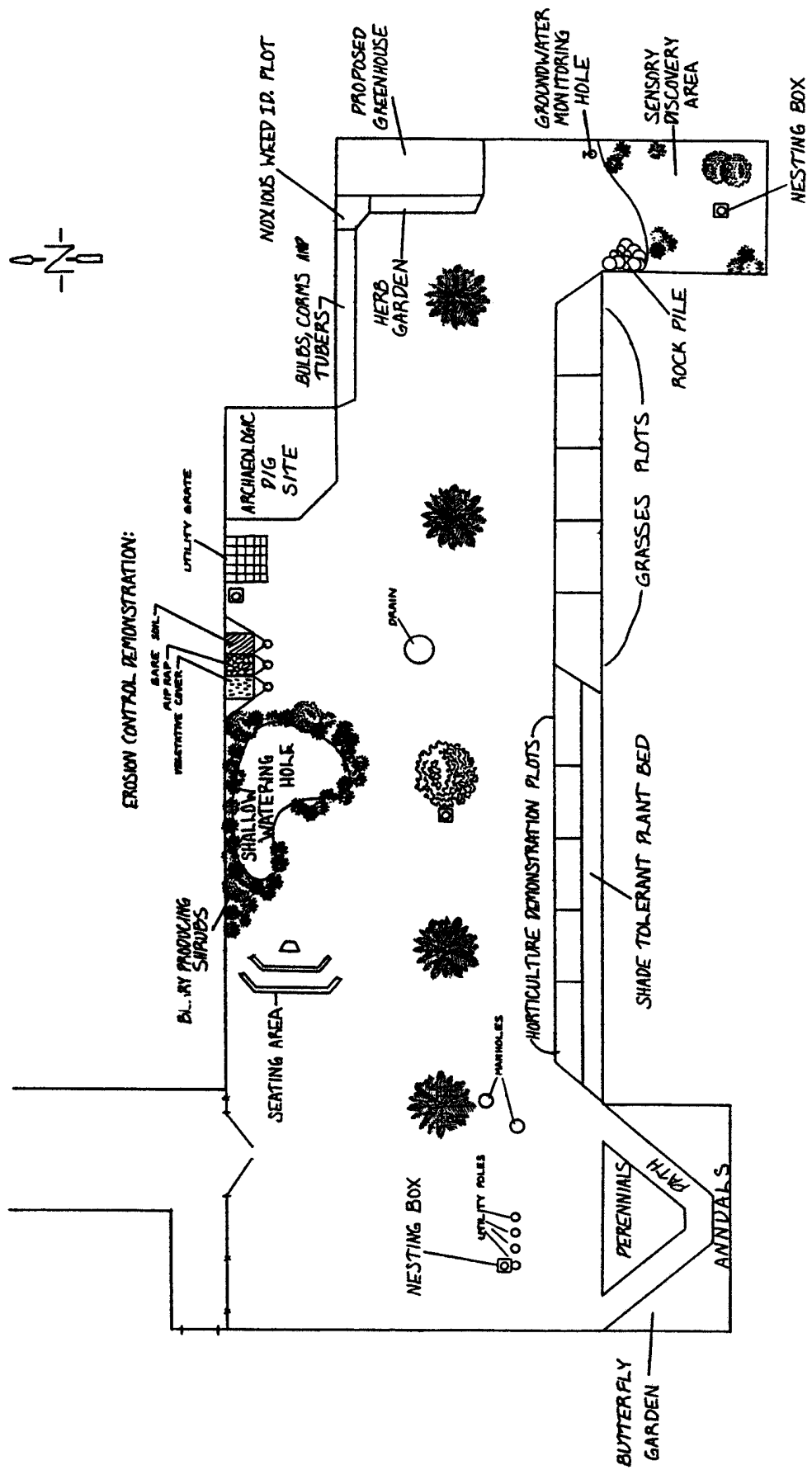

Enclosed Courtyard

**COURTYARD A:
FORMAL THEME**

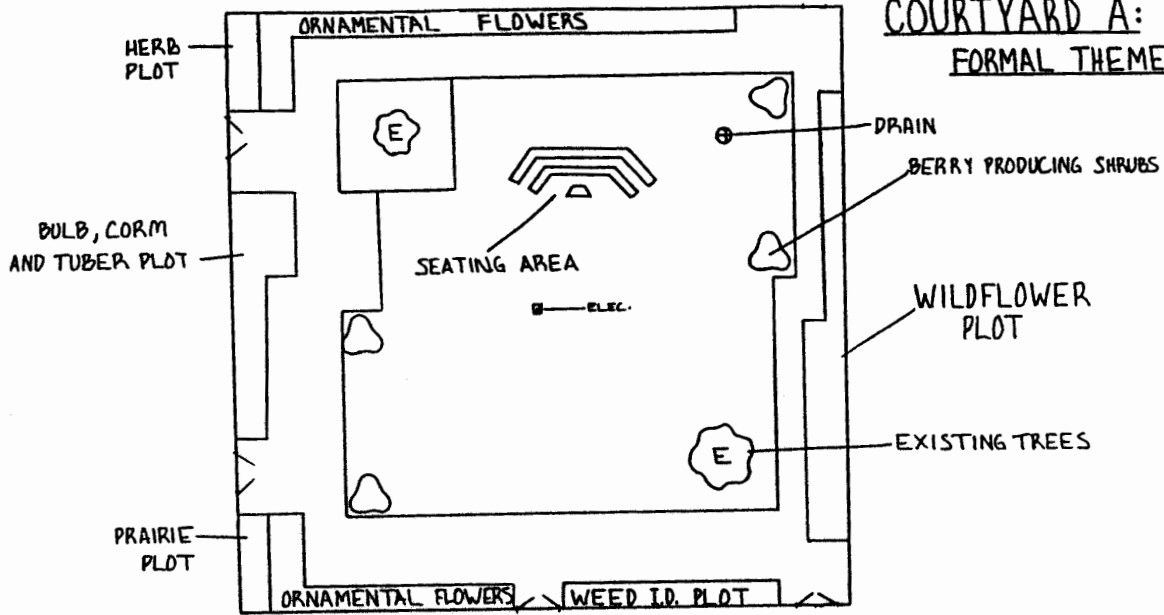

**COURTYARD B:
BIRD FEEDING AND
NESTING THEME**

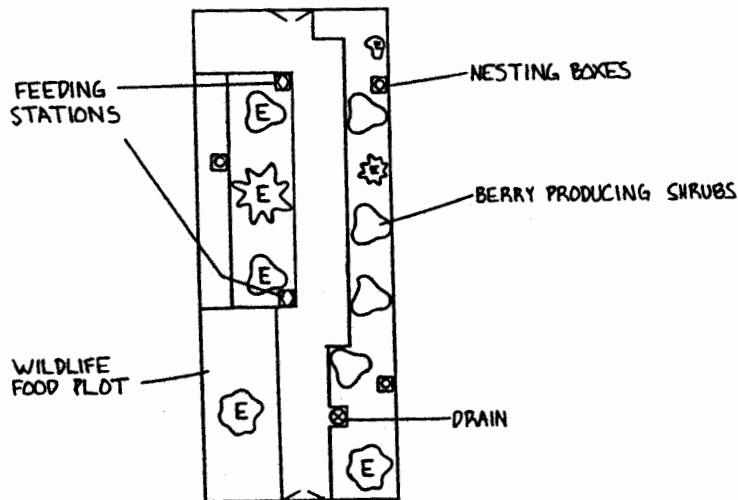

**COURTYARD C:
INDIAN THEME**

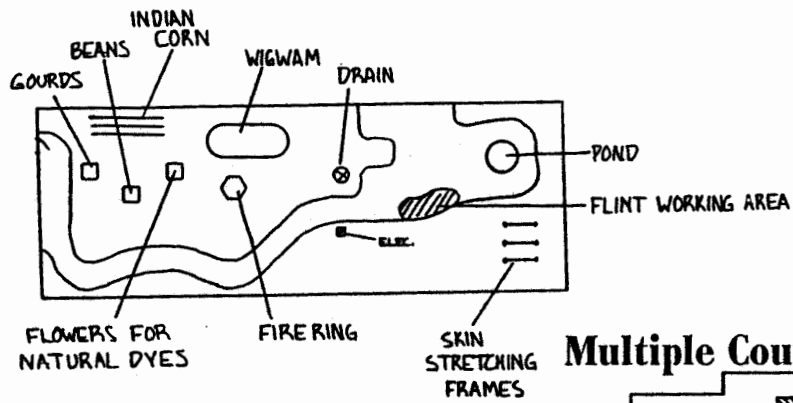

Multiple Courtyards

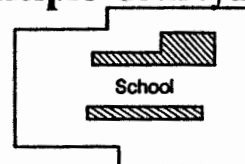

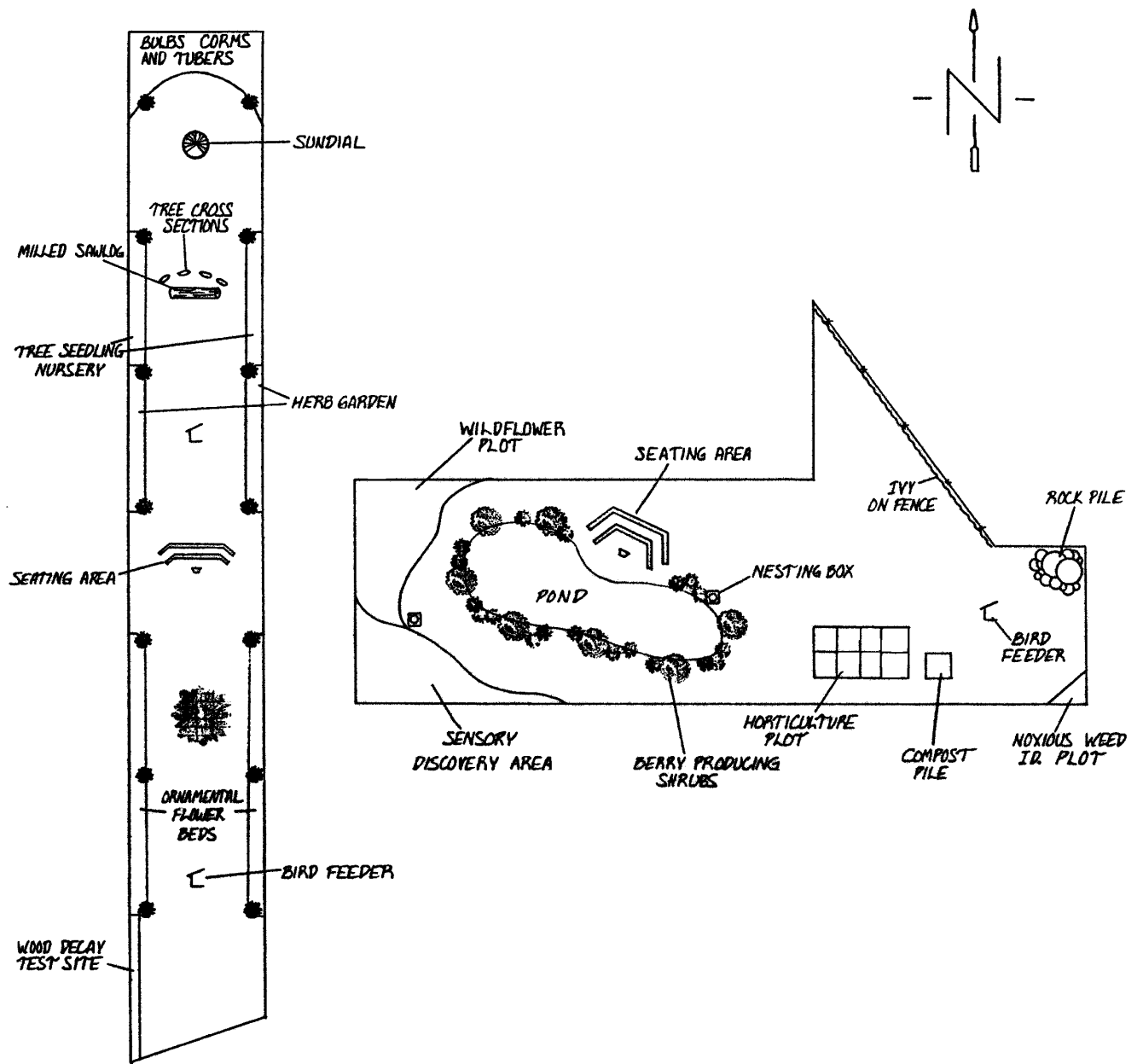

Multiple Courtyards

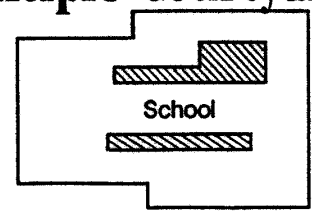



PREHISTORIC THEME COURTYARD

INDIAN THEME COURTYARD

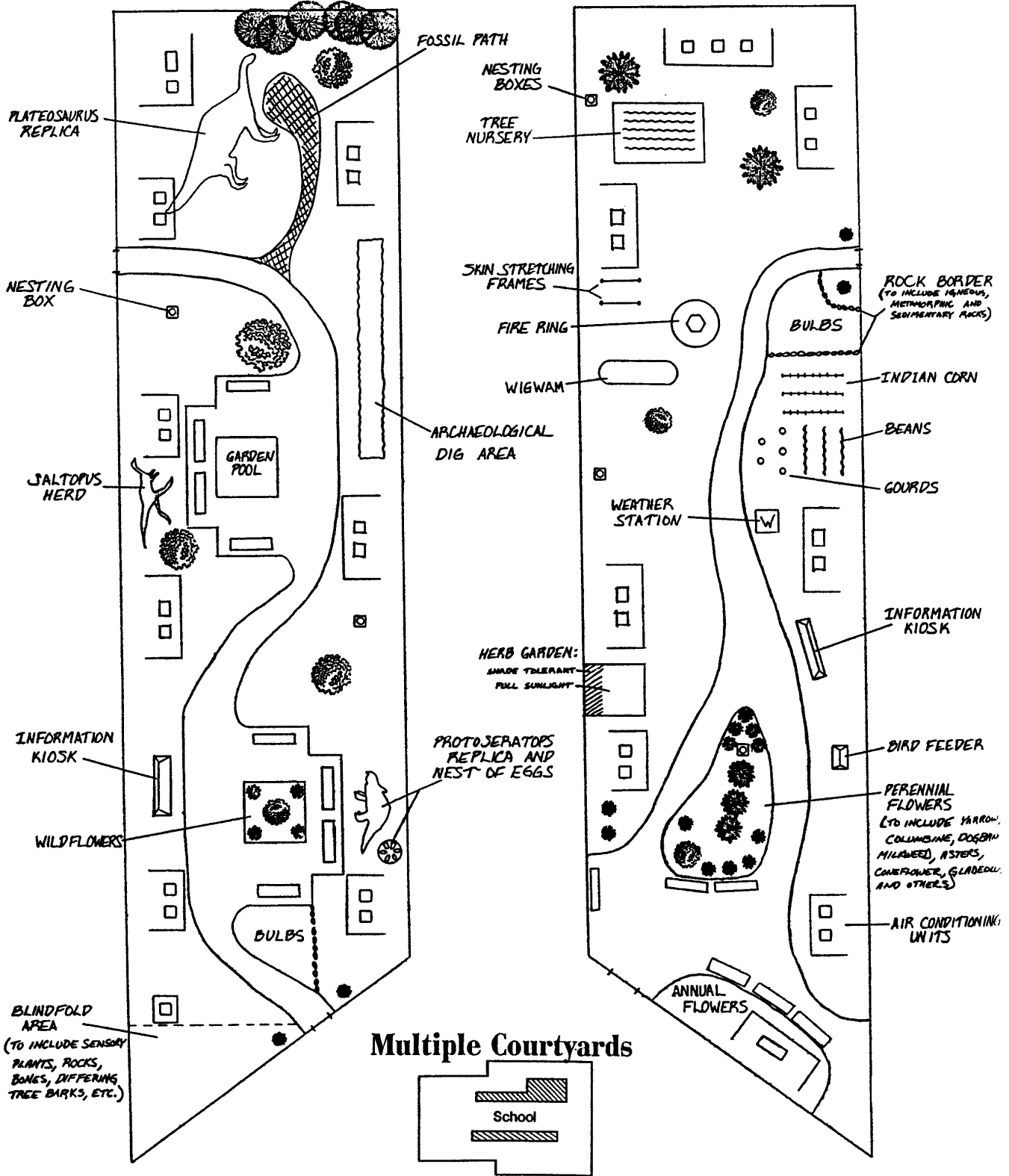

SCHOOL STREET

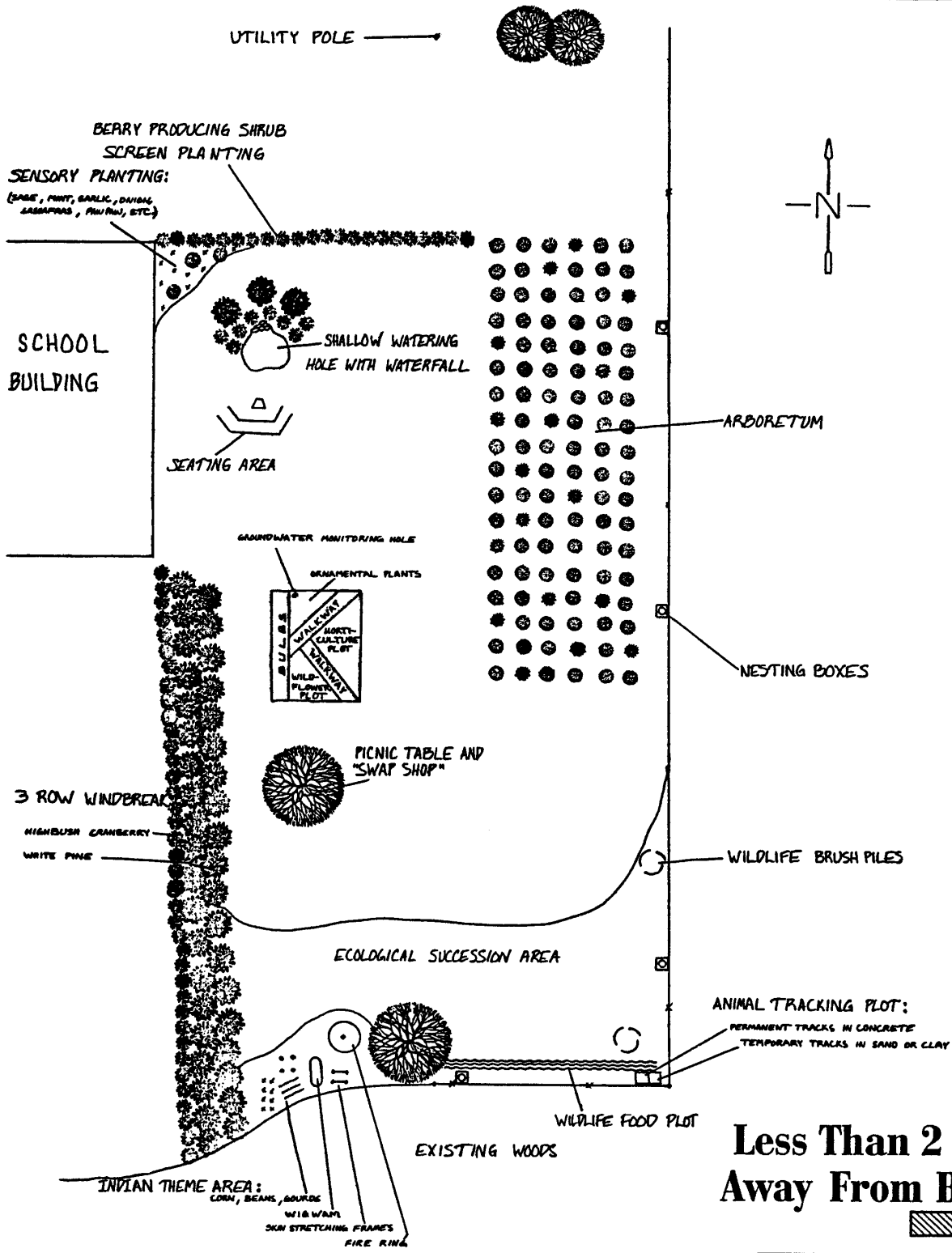

**Less Than 2 Acres,
Away From Building**

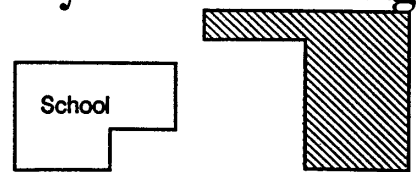

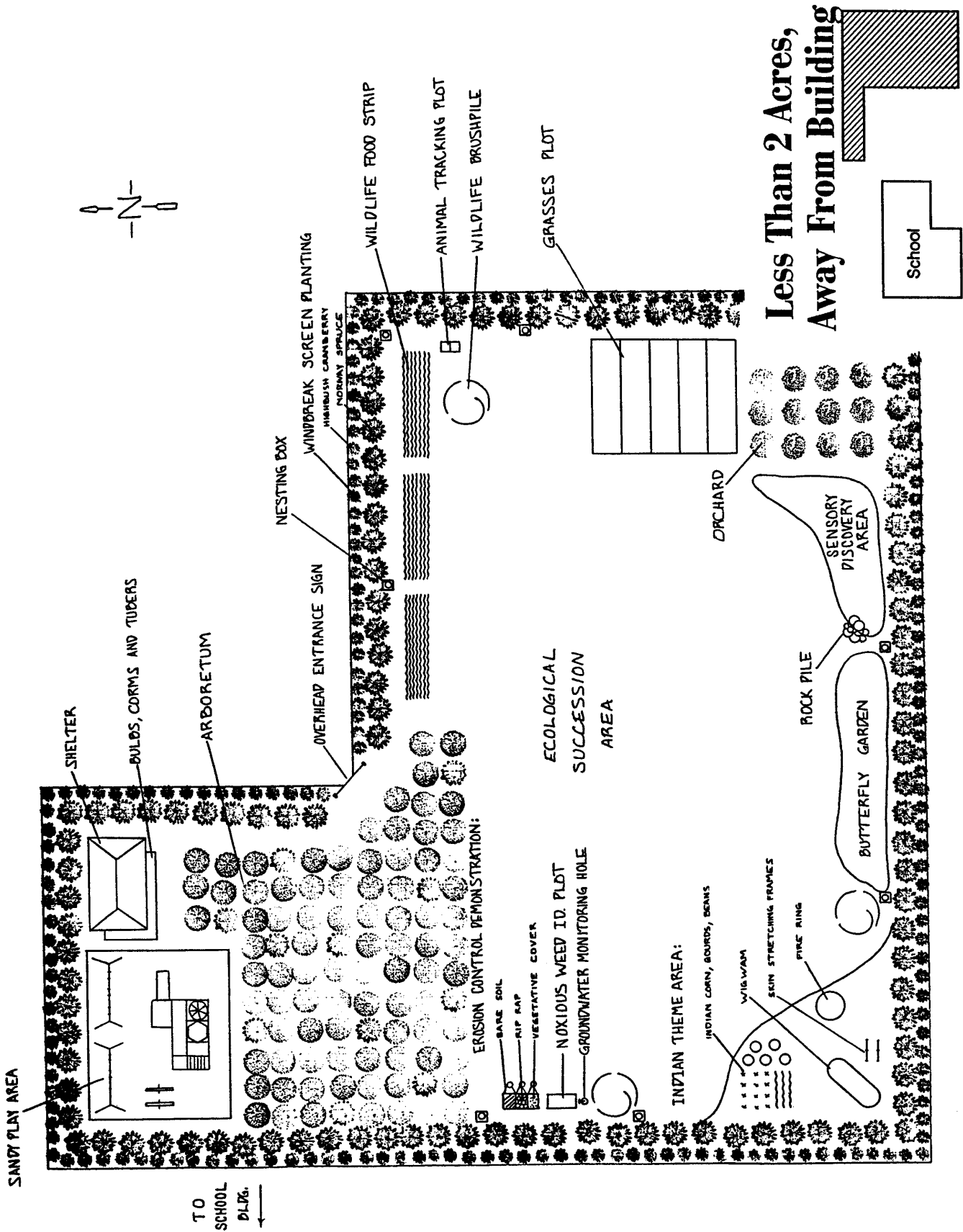

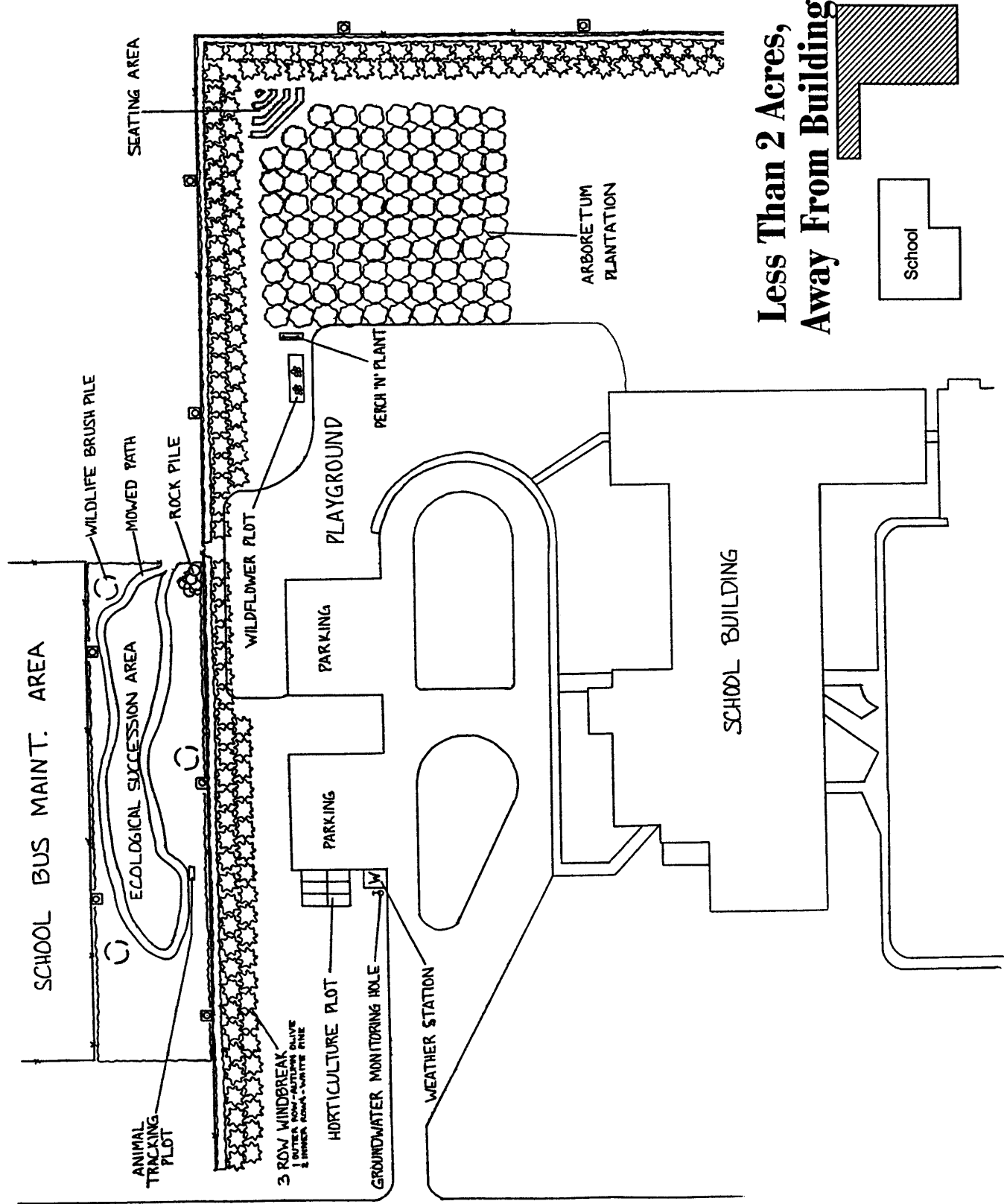

**Less Than 2 Acres,
Away From Building**

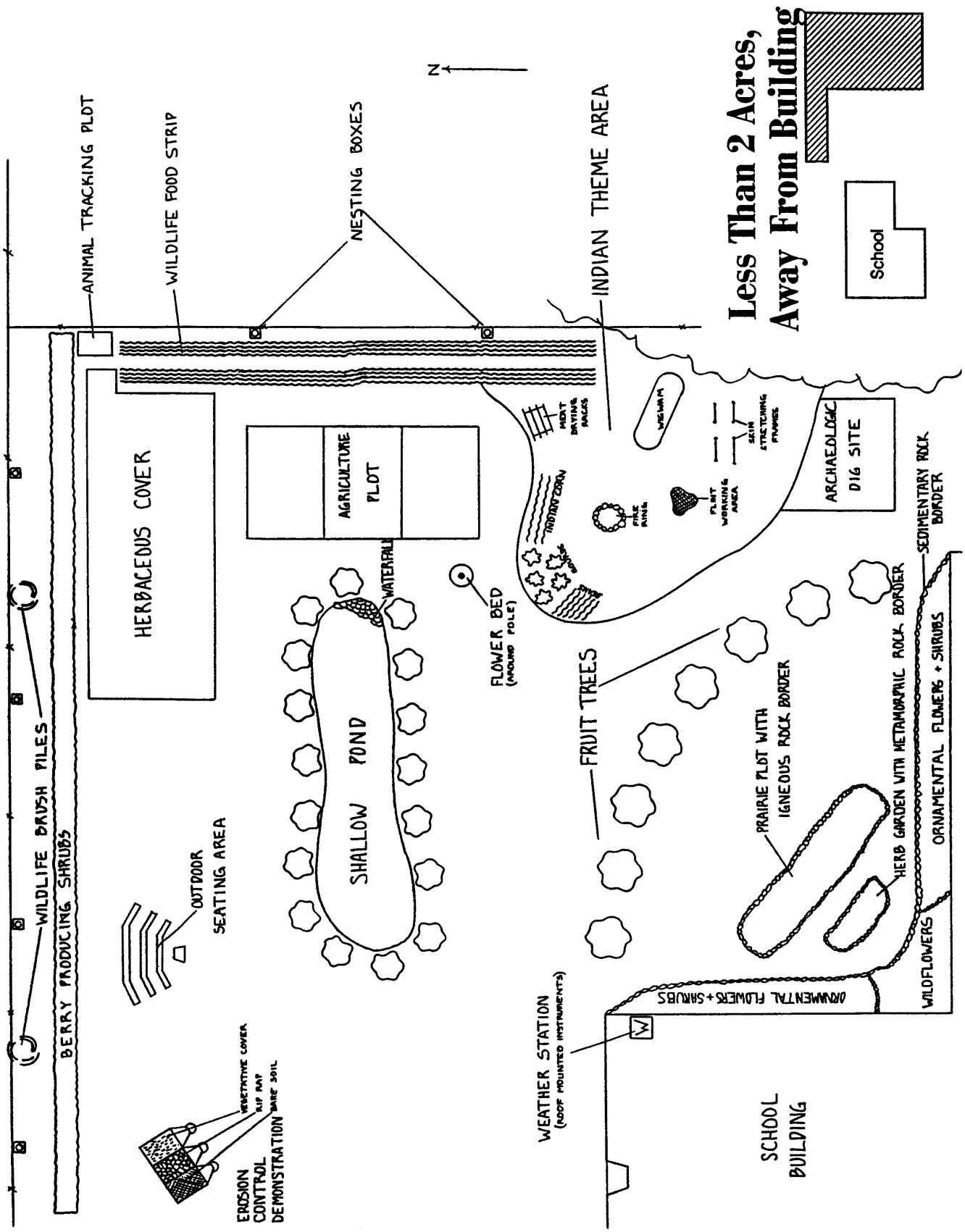

Less Than 2 Acres, Away From Building

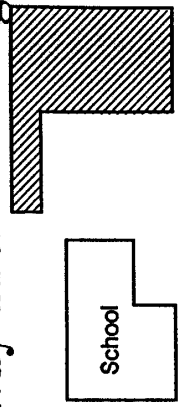

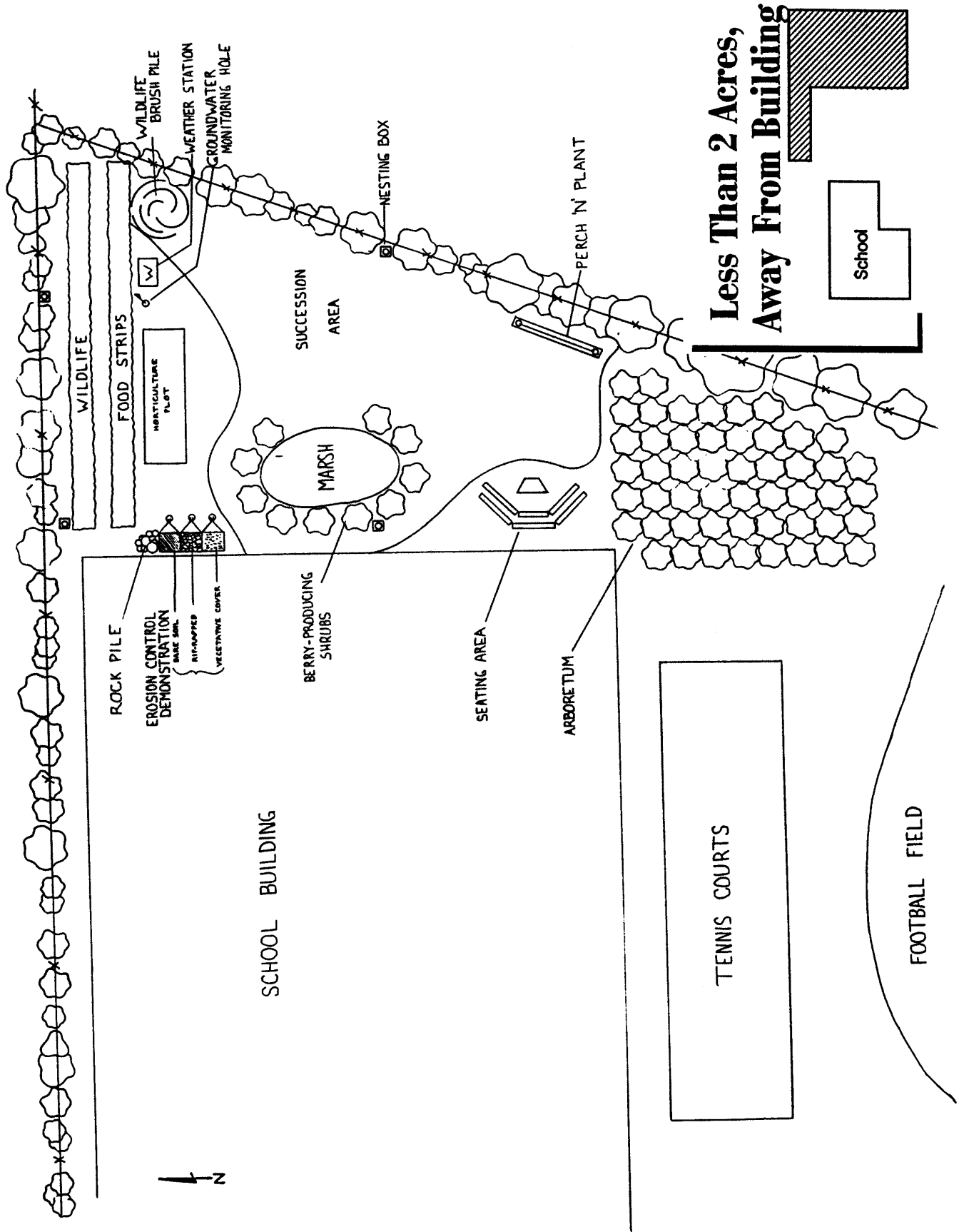

**Less Than 2 Acres,
 Away From Building**

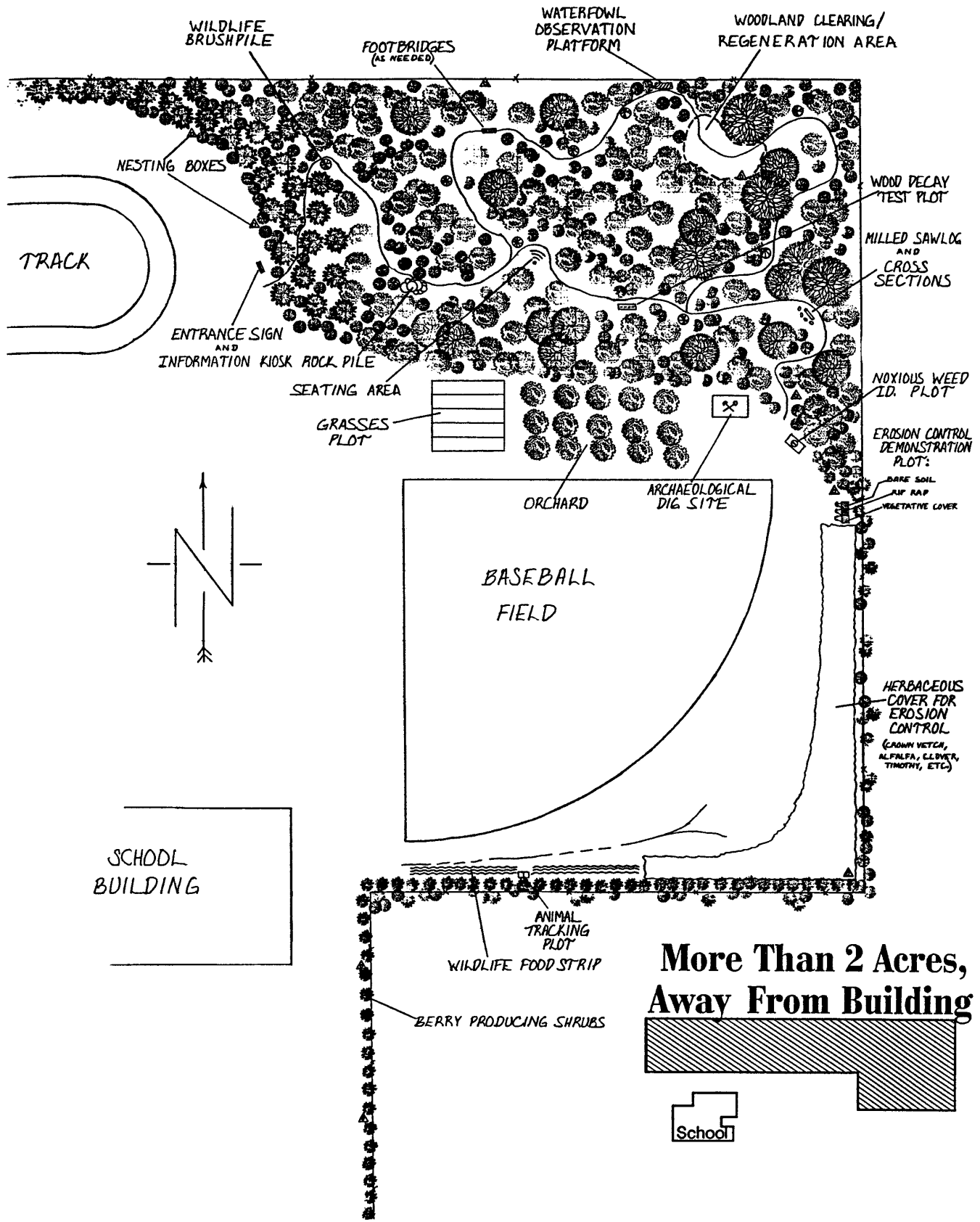

**More Than 2 Acres,
Away From Building**

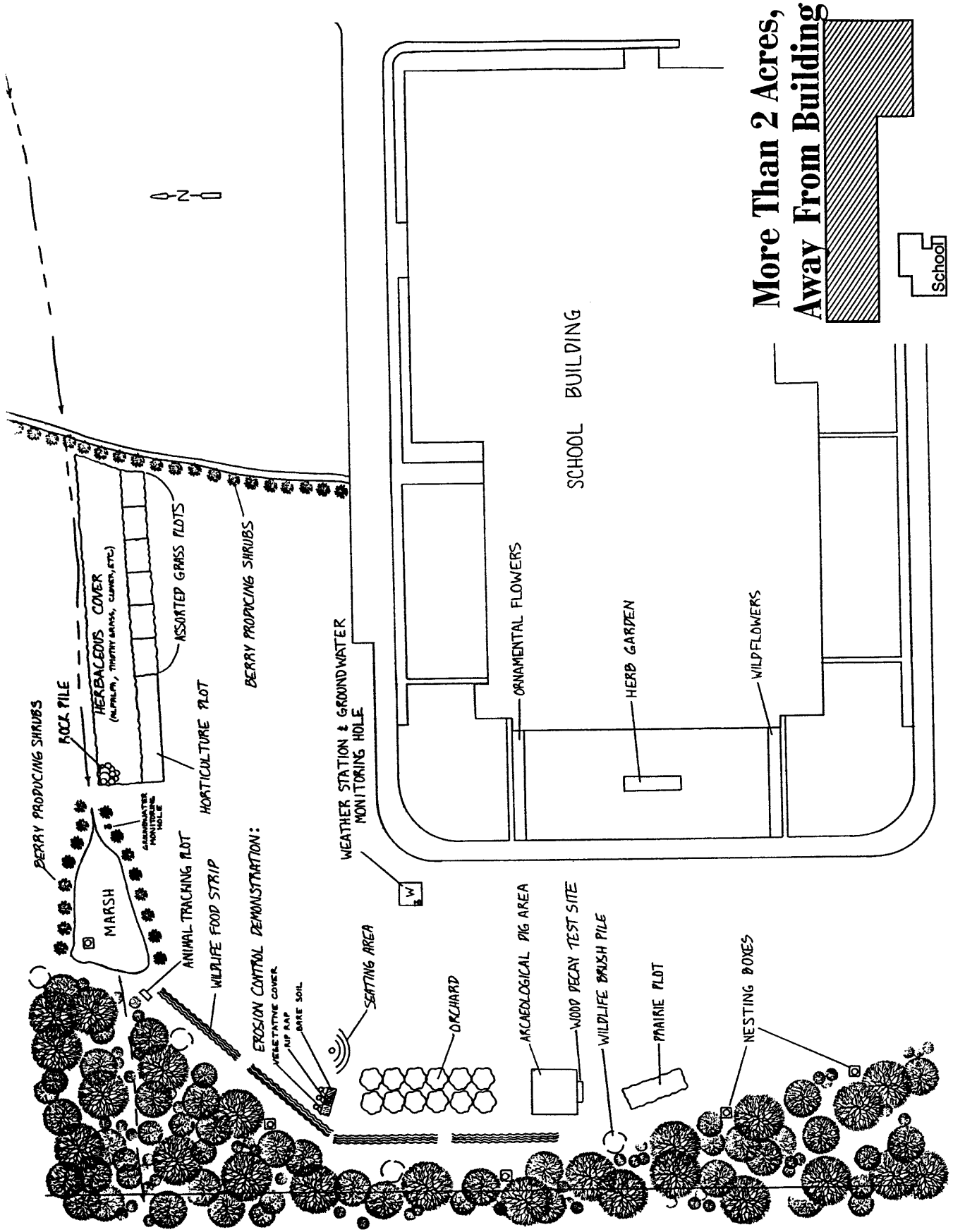

More Than 2 Acres,
 Away From Building



BASEBALL FIELDS

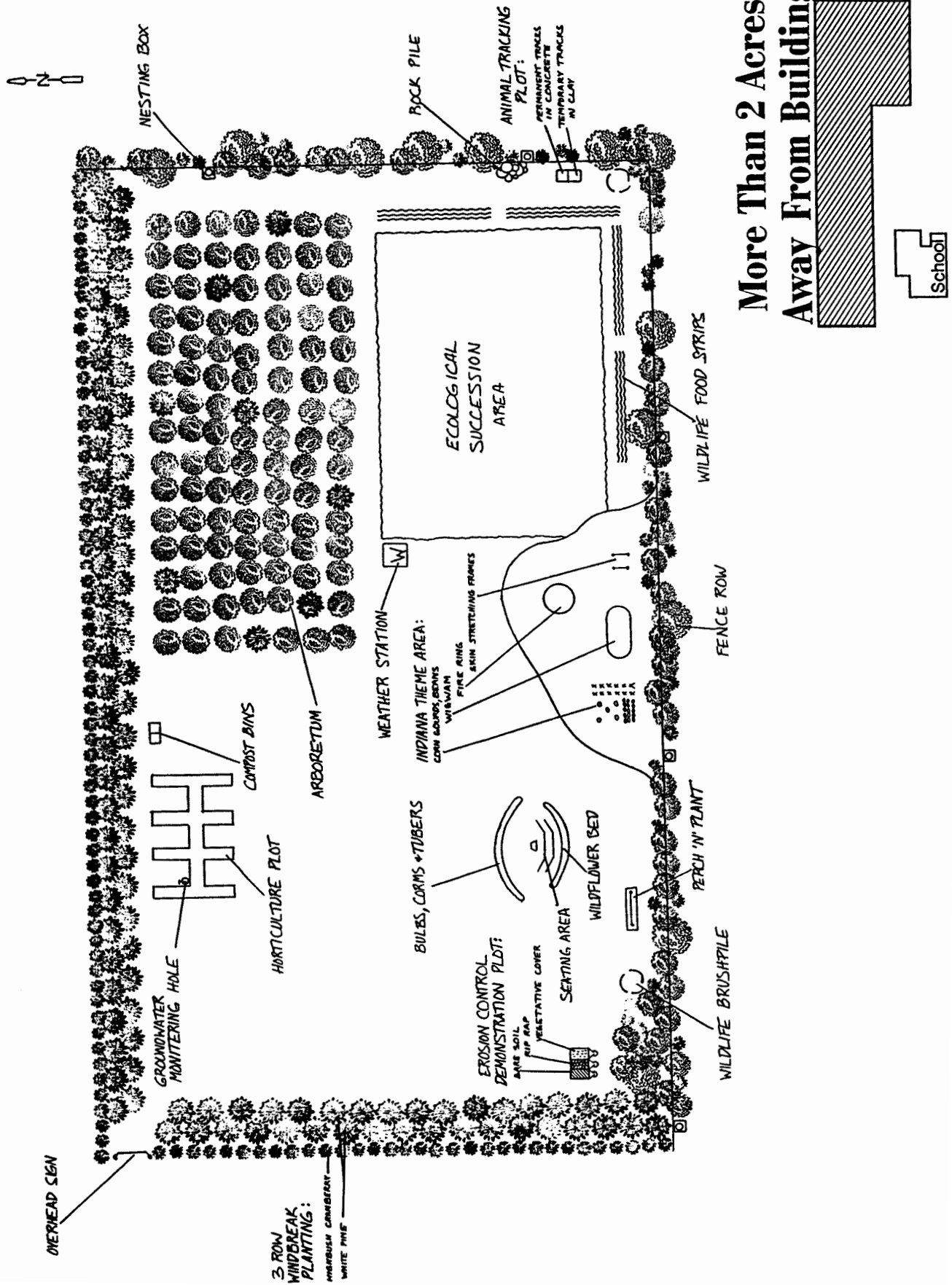

More Than 2 Acres,
Away From Building

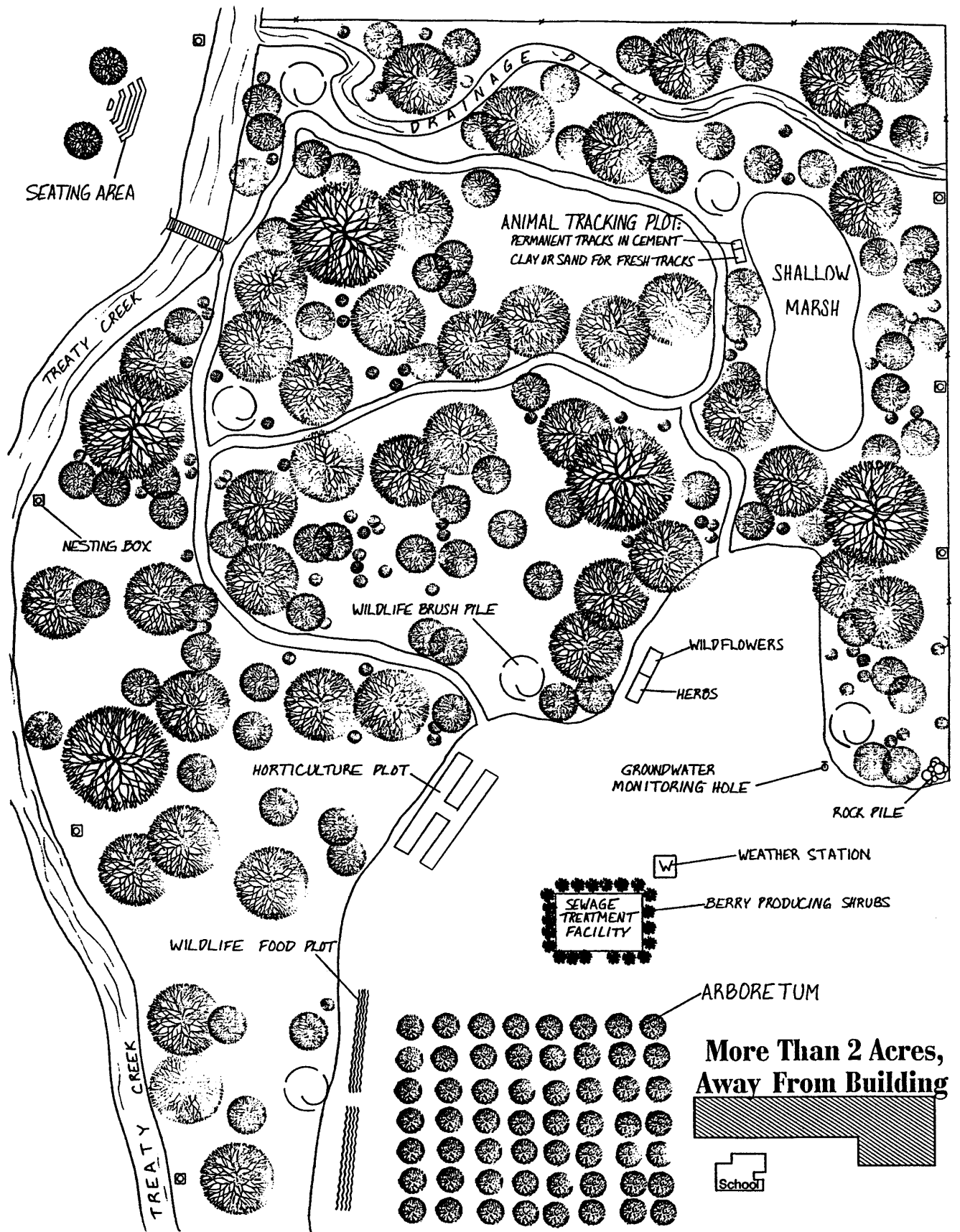

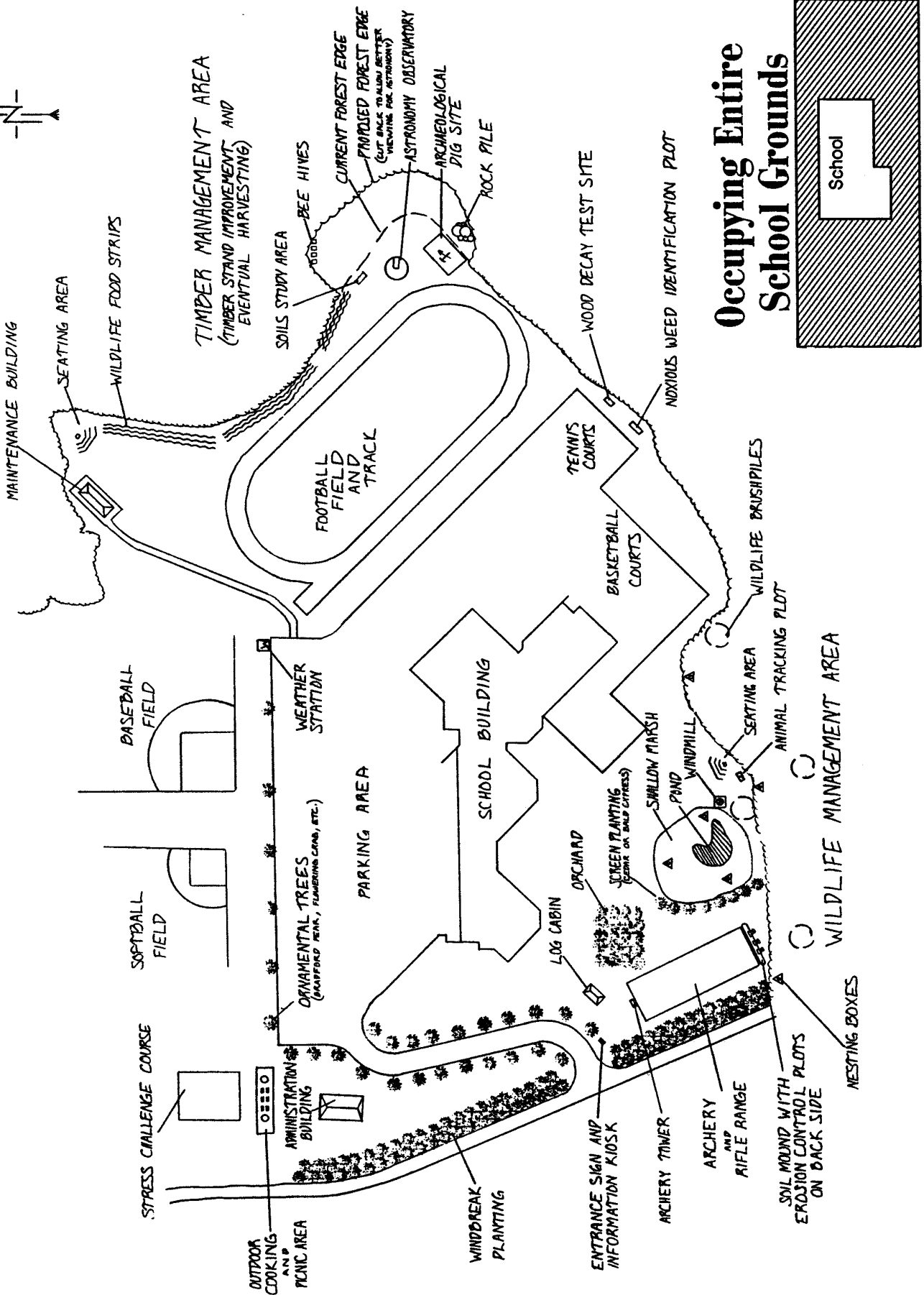
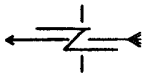

Occupying Entire School Grounds

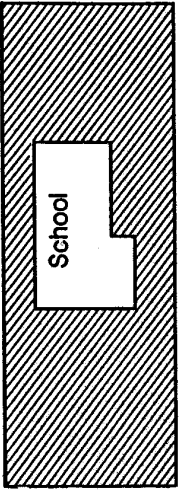

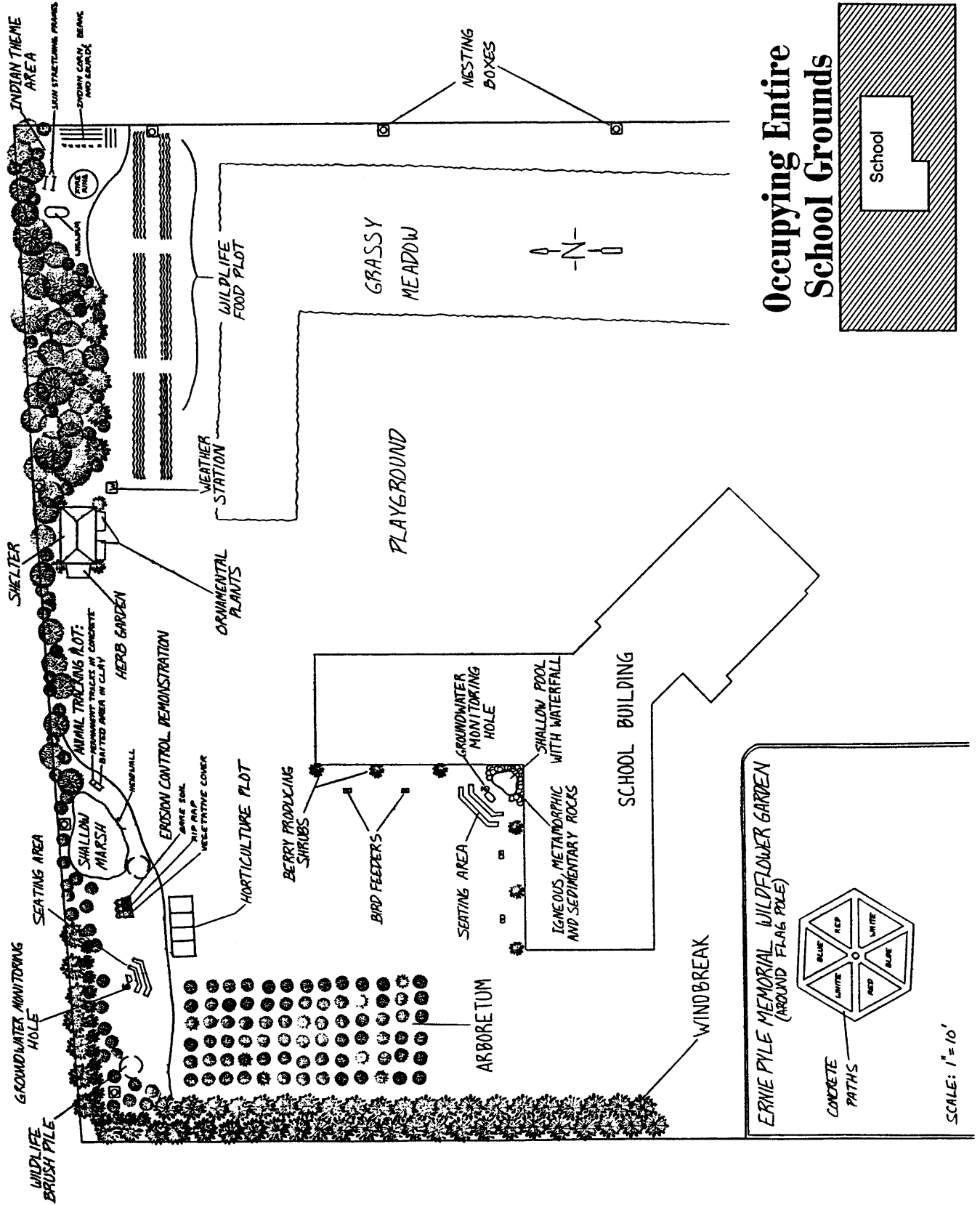

Occupying Entire School Grounds

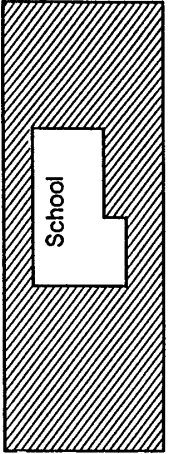

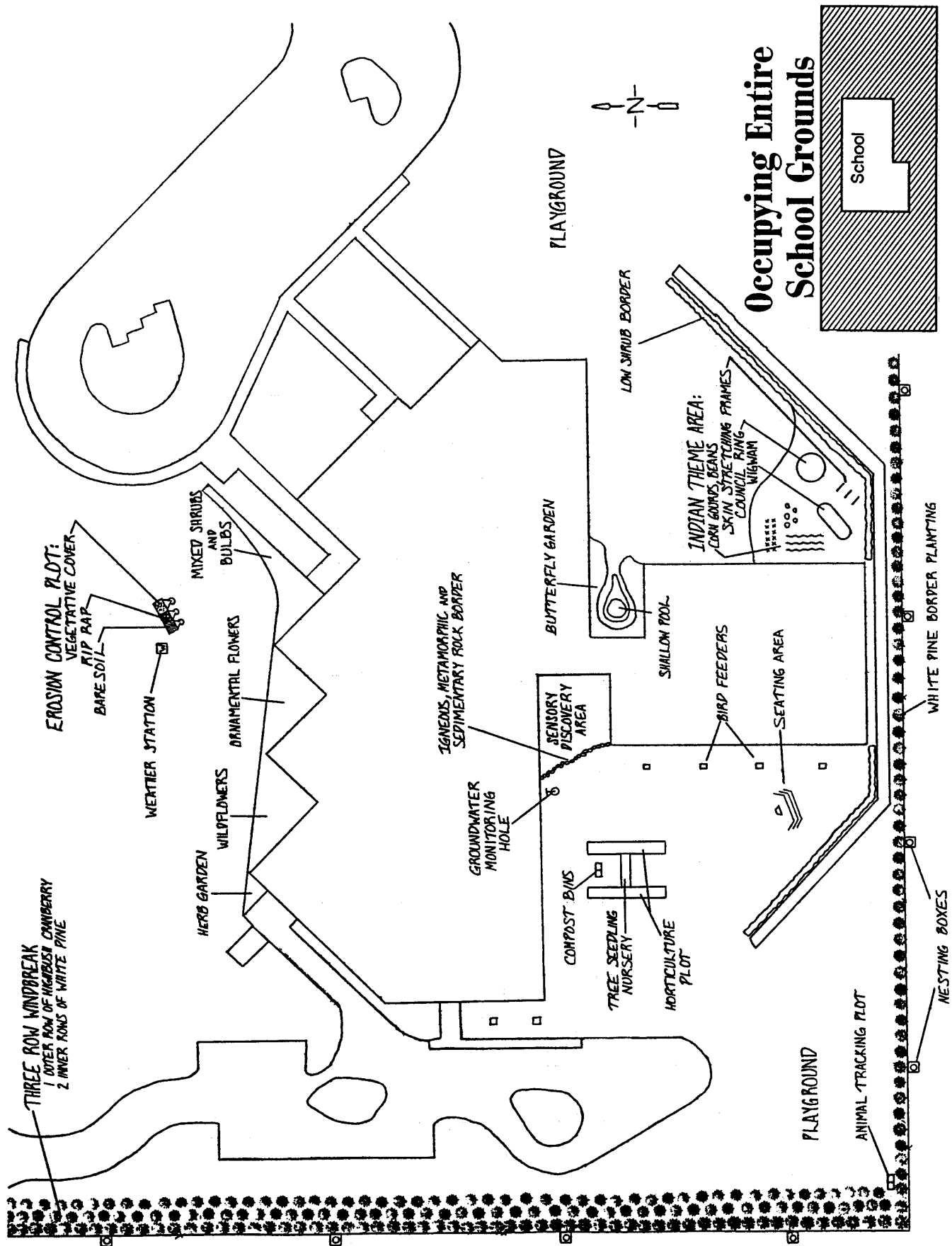

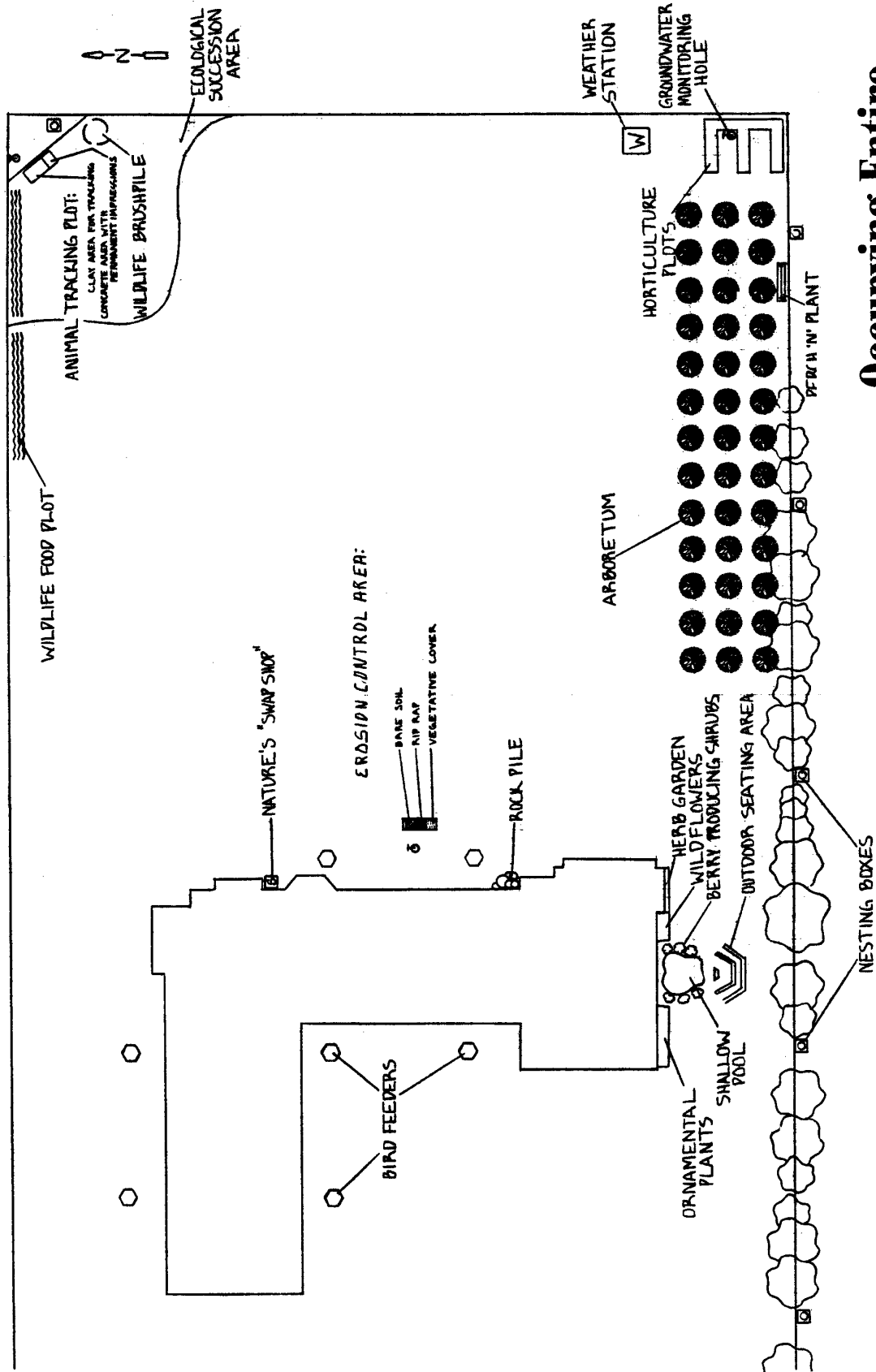

Occupying Entire School Grounds

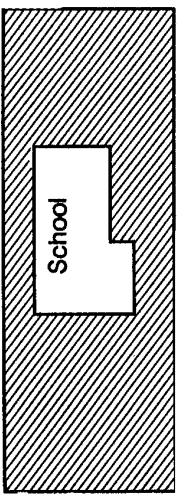

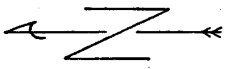
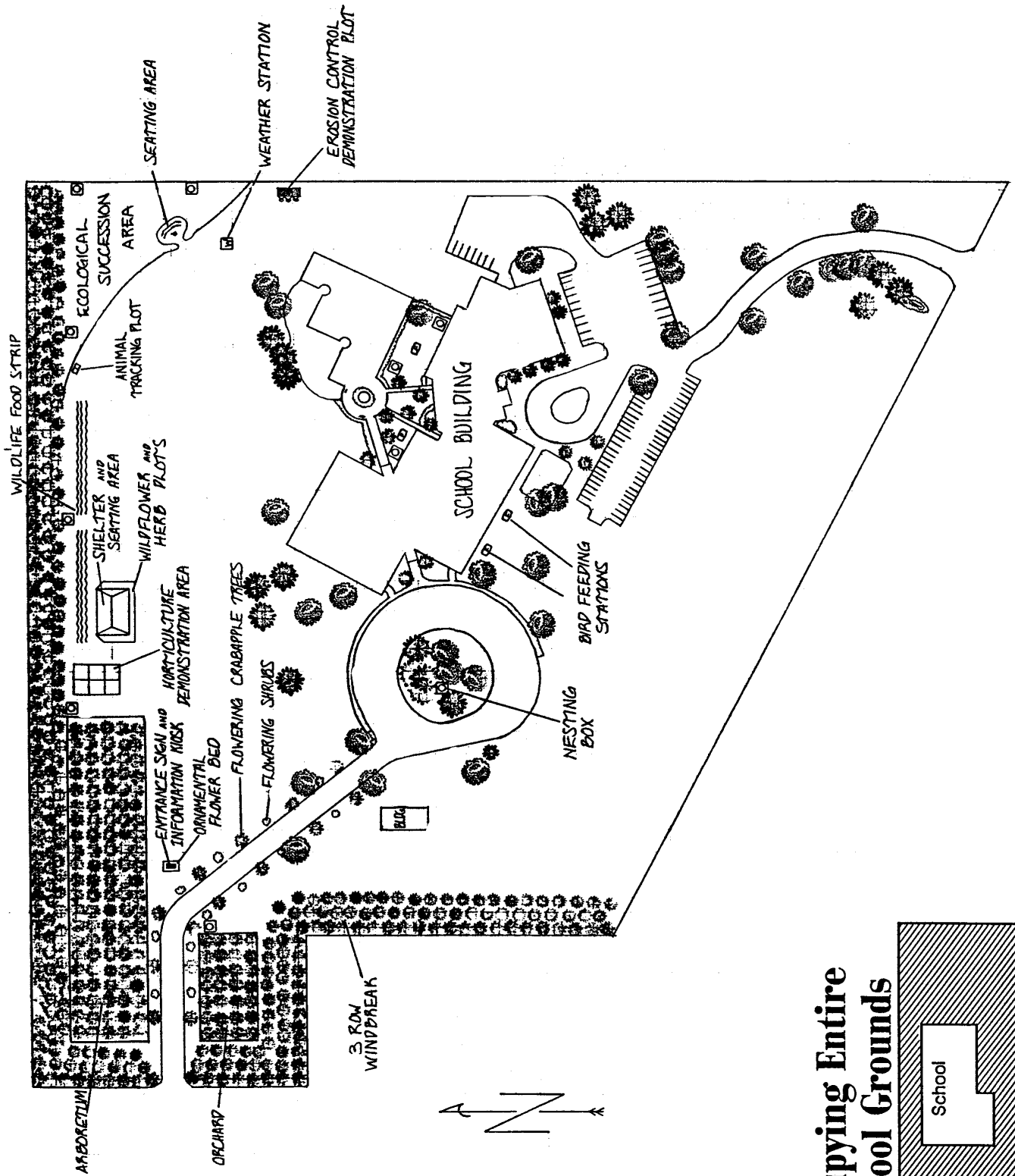

Occupying Entire School Grounds

